

# E-HLD Shear Load Connectors

For the connection of new slabs to diaphragm walls or secant pile walls in basement construction

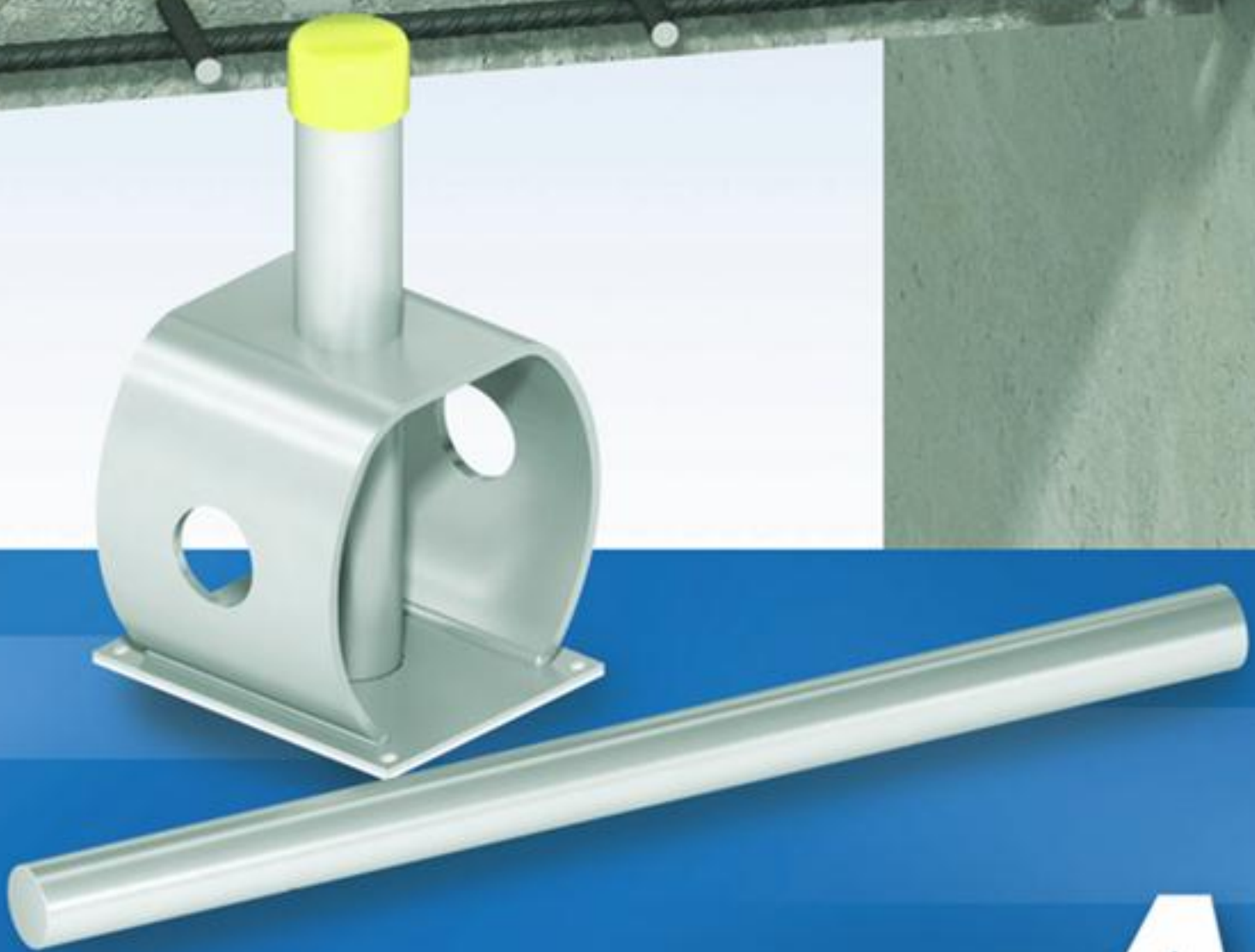

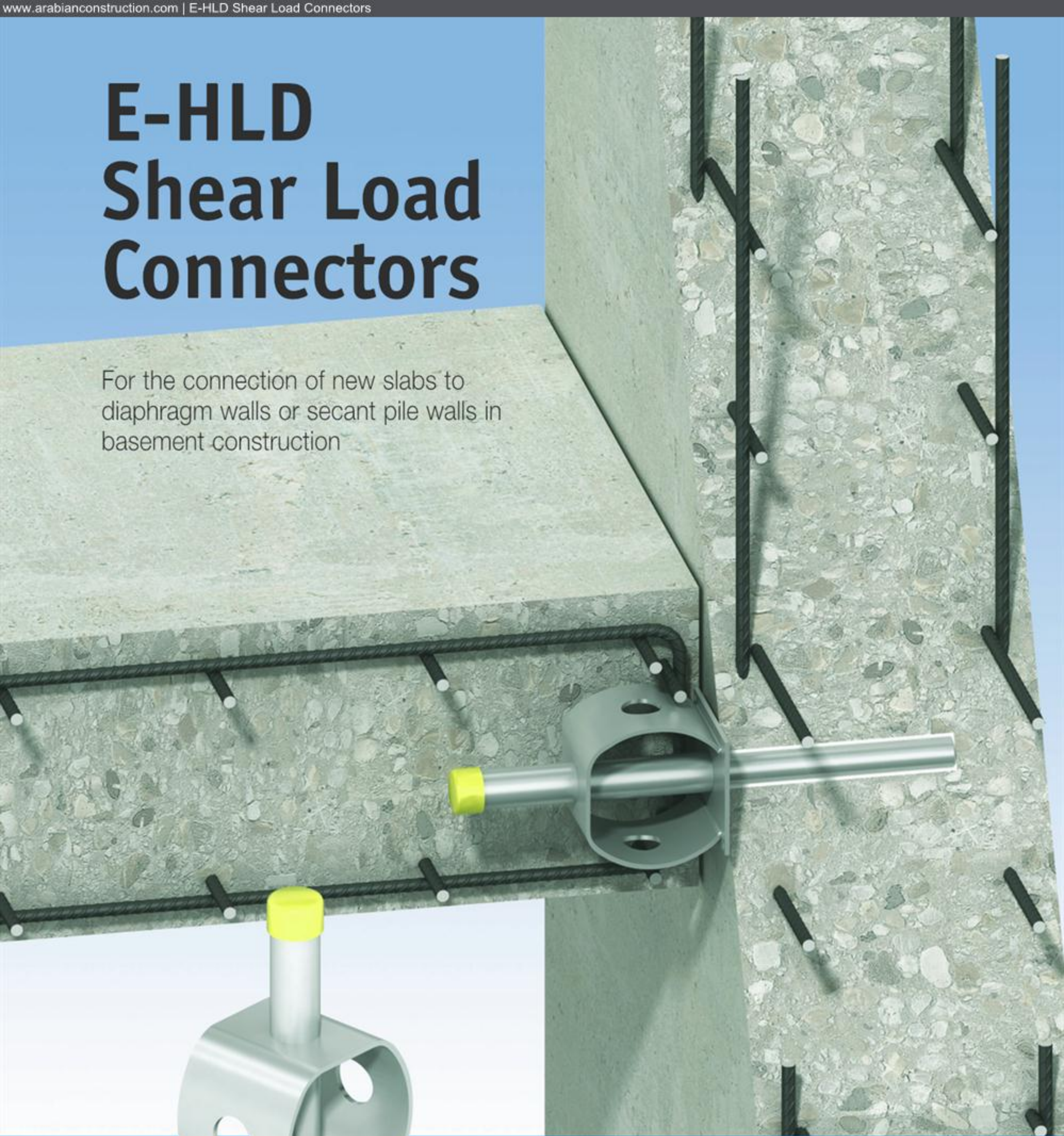

# Ancon E-HLD Shear Load Connector

The Ancon E-HLD joins new concrete slabs to existing concrete walls. It is designed to transfer shear load where new slabs are connected to diaphragm walls or secant pile walls in basement construction\*.

The E-HLD comprises a stainless steel dowel and a high strength, stainless steel sleeve. It is available in seven standard sizes and can be used in a slab thickness from 160mm and joints up to 60mm wide. Ancon two-part resin is required to install the dowel component. The quantity of resin cartridges required will depend on dowel diameter and number being fixed.

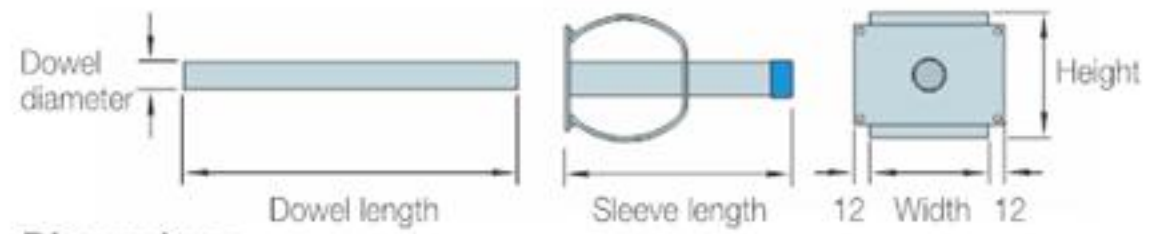

## Dimensions

Product Reference	Dowel Component		Sleeve Component		
	Diameter	Length	Length	Height	Width
E-HLD 18	18	270	155	75	70
E-HLD 22	22	300	165	95	90
E-HLD 24	24	330	175	110	100
E-HLD 30	30	350	190	140	115
E-HLD 35	35	400	215	160	132
E-HLD 42	42	470	245	180	175
E-HLD 52	52	570	295	220	210

## Performance

Minimum Slab Thickness B (mm)	Product Reference	F <sub>rd</sub> Design Capacities (kN) for Various Joint Widths (mm) using C25/30 Concrete					
		10	20	30	40	50	60
160	E-HLD 18	41.8	36.8	30.1	25.0	21.4	18.7
180	E-HLD 22	69.6	59.2	50.5	42.6	36.8	32.4
200	E-HLD 24	83.1	71.7	62.2	53.6	46.5	41.1
240	E-HLD 30	120.2	106.2	94.2	83.3	73.2	65.2
300	E-HLD 35	165.7	148.6	133.8	120.4	107.3	96.3
350	E-HLD 42	200.8	182.5	166.4	151.6	136.9	123.8
400	E-HLD 52	302.3	280.0	260.1	242.2	225.9	210.8

## Edge Distance and Spacing - Second Phase

The minimum edge distance is determined by the depth of the adjoining slab.



## Local Reinforcement - Second Phase

Product Reference	Options for Main Reinforcement (No. of U-bars each side)					
	H8	H10	H12	H14	H16	H20
E-HLD 18	3	2	2	-	-	-
E-HLD 22	-	3	3	2	-	-
E-HLD 24	-	-	3	2	2	-
E-HLD 30	-	-	4	3	3	-
E-HLD 35	-	-	-	4	3	2
E-HLD 42	-	-	-	4	4	3
E-HLD 52	-	-	-	-	5	3

Product Reference	Options for Longitudinal Reinforcement (No. of bars top and bottom)					
	H8	H10	H12	H14	H16	H20
E-HLD 18	2	2	-	-	-	-
E-HLD 22	3	2	2	-	-	-
E-HLD 24	-	2	2	2	-	-
E-HLD 30	-	-	3	2	2	-
E-HLD 35	-	-	3	2	2	-
E-HLD 42	-	-	-	2	2	2
E-HLD 52	-	-	-	3	2	2

**Note:** The longitudinal reinforcement assumes that the E-HLDs are positioned at one metre centres.



## Ancon Building Products

President Way, President Park, Sheffield S4 7UR, United Kingdom,  
 Tel: +44 (0) 114 275 5224, Fax: +44 (0) 114 276 8543  
 Email: info@ancon.co.uk Visit: www.ancon.co.uk

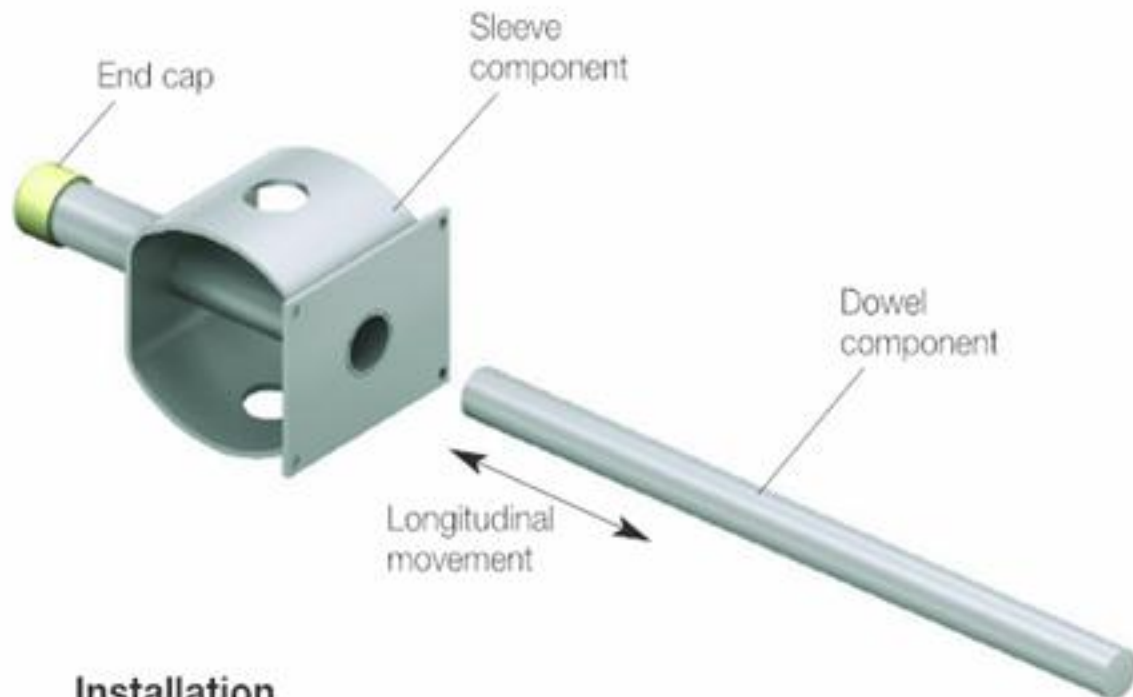

## Installation

First phase - The dowel component is resin-fixed in the wall

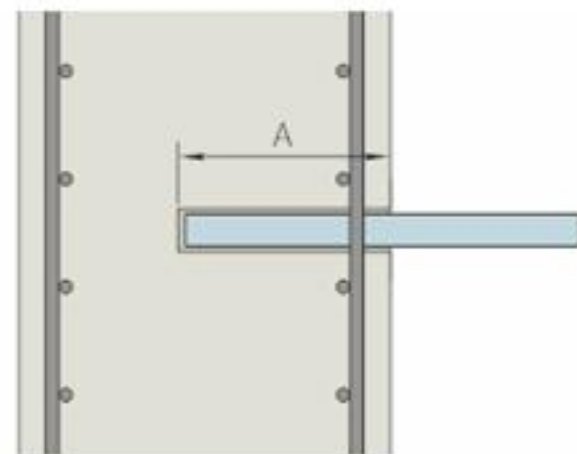

A hole should be drilled no more than 5mm wider than the dowel, to the depth shown in the table. Ancon's two-part resin is injected into the hole and the dowel is inserted.

Dowel Diameter (mm)	18	22	24	30	35	42	52
Depth A (mm)	130	155	170	180	205	240	290
Approx. No. Dowels per Cartridge	16	10	9	6	4	3	2

Second phase - The sleeve component is installed.

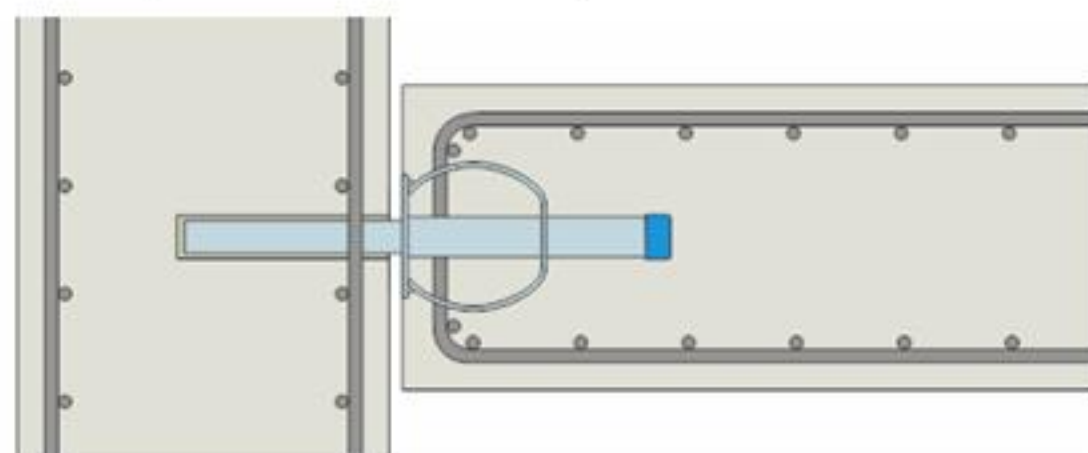

Once the resin reaches full strength, the sleeve component is pushed over the exposed end of the dowel. The required local reinforcement is located around the sleeve, ensuring that the correct cover is maintained. The concrete is cast to complete the installation.

\*In applications where movement needs to be accommodated, please contact Ancon.