

CI/SIB	(29)	E16	
September 2012			

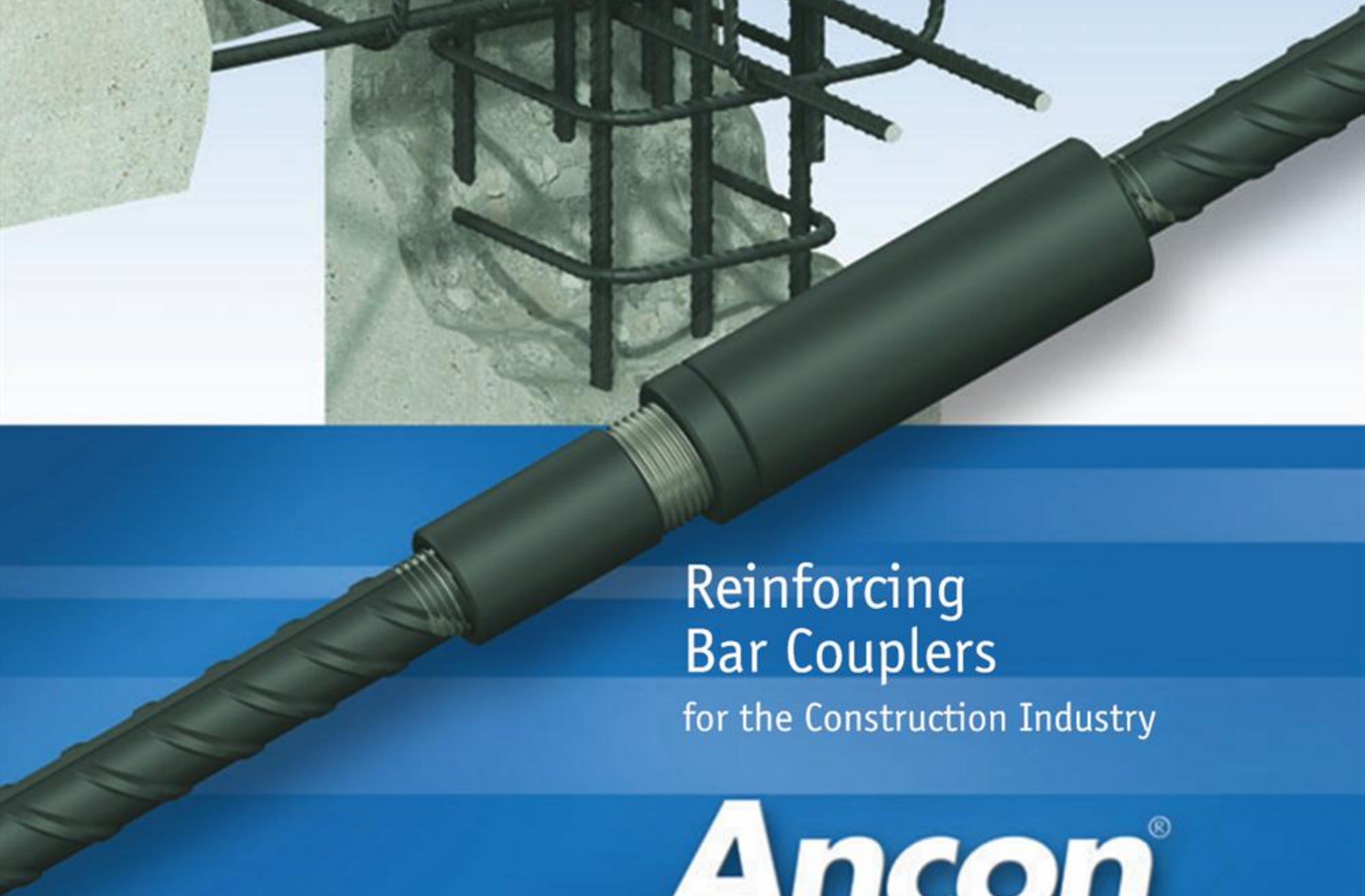
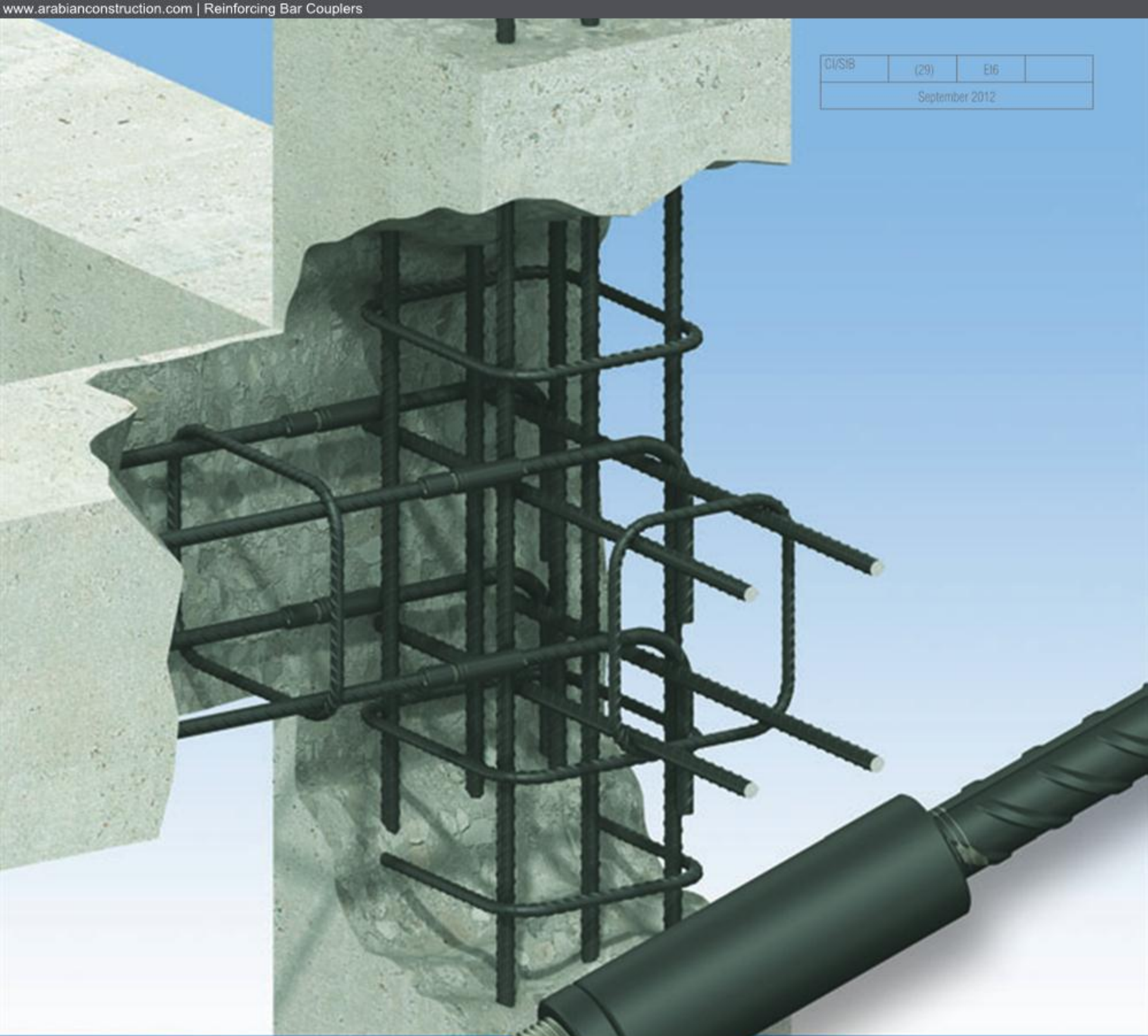

Reinforcing Bar Couplers

for the Construction Industry

Ancon[®]
BUILDING PRODUCTS

Reinforcing Bar Couplers

Simplify the design and construction of concrete

Lapped joints are not always an appropriate means of connecting reinforcing bars. The use of laps can be time consuming in terms of design and installation and can lead to greater congestion within the concrete because of the increased amount of rebar used.

Ancon couplers can simplify the design and construction of reinforced concrete and reduce the amount of reinforcement required.

Lapped joints are dependent upon the concrete for load transfer. For this reason any degradation in the integrity of

the concrete could significantly affect the performance of the joint. The strength of a mechanical splice is independent of the concrete in which it is located and will retain its strength despite loss of cover as a result of impact damage or seismic event.

The Ancon range of reinforcing bar couplers is the most comprehensive available and includes tapered threaded, parallel threaded and mechanically bolted couplers.



Contents

Coupler Selection	5-6	Bartec Series	16-19
Typical Coupler Applications	7	Bar X-L Series	20-23
Tapered Thread Standard Series	8-9	MBT ET Series	24-25
Tapered Thread Positional Series	10-11	MBT Transition Series	26
Tapered Thread Transition Series	12	MBT Continuity Series	27-29
Tapered Thread Starter Bars	13	MBT Headed Anchors	30
Tapered Thread Weldable Series	14	MBT Electric Wrench	31
Tapered Thread Headed Anchors	15	Other Ancon Products	31

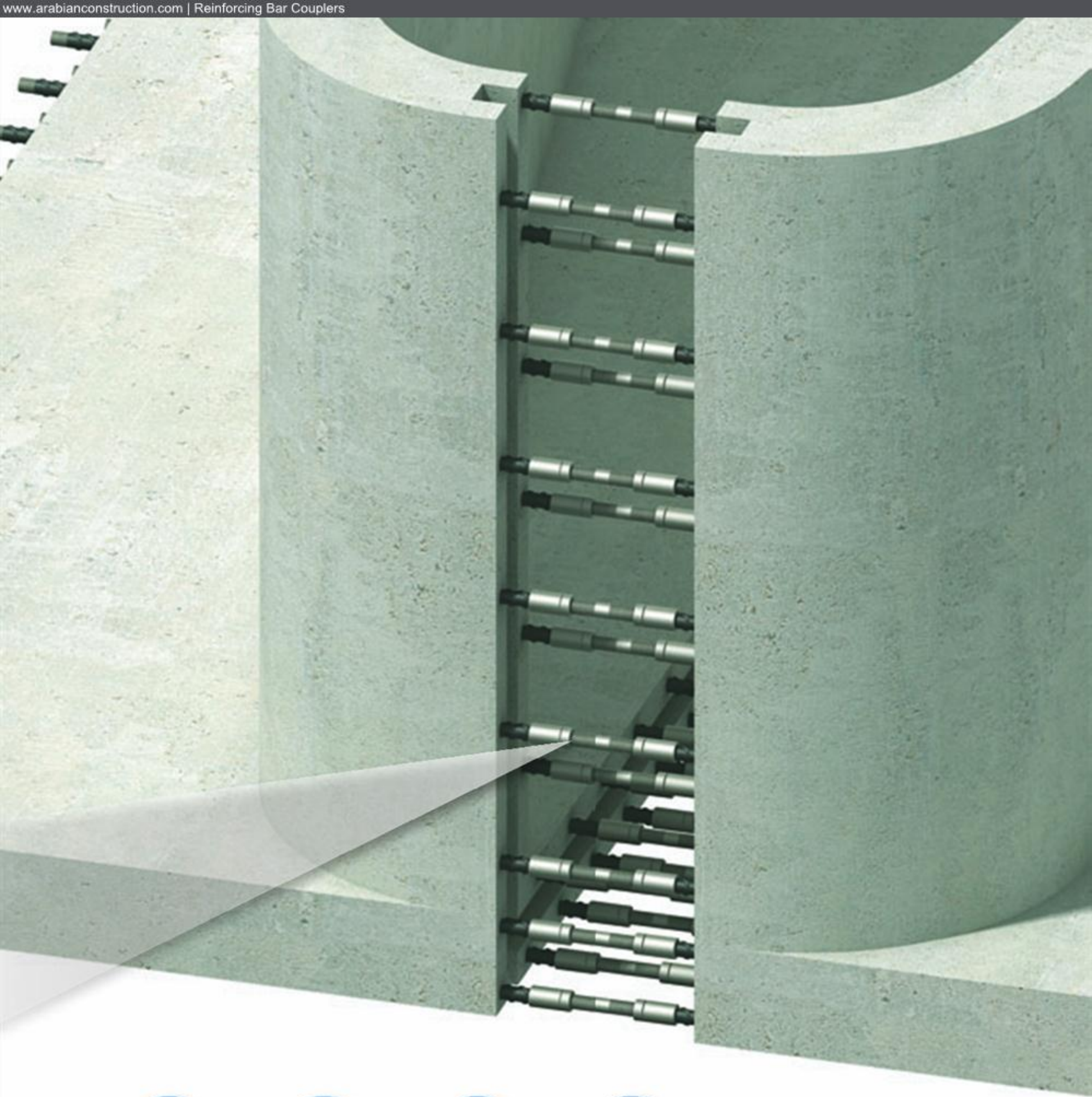

Comprehensive Range



Eurocode 2 compliant



Simplify design and construction



Reduce amount of reinforcement required



Dedicated sales support



Available through major rebar stockists and approved distributors



ISO 9001, ISO 14001, OHSAS 18001



Technical approval TA1-B 5015 for Tapered Thread Couplers



Reinforcing Bar Couplers

For many years the use of mechanical couplers to join reinforcing bars has been regarded as a means of reducing the use of long bars. Engineers and contractors now recognise the benefits of using couplers to accelerate the speed of construction, increase productivity and simplify design details.

Sales Support

Ancon's 'Products for Structural Concrete' Division provides assistance for clients who require products which are used in structural concrete construction. These include, but are not restricted to, reinforcing bar couplers, reinforcement continuity systems, punching shear reinforcement and shear load connectors. A dedicated team is available to offer technical advice, pricing information and guidance on the selection of the most appropriate product for a specific application.

Enquiries from overseas are also dealt with by the PSC team. To contact the team please email concrete@ancon.co.uk or call +44 (0) 114 275 5224.



Characteristic Strengths of High Yield Reinforcing Bar

Diameter (mm)	Area (mm ²)	Fy(kN) 500N/mm ²
10	78.5	39.3
12	113	56.5
14	154	77.0
16	201	100.5
18	254	127.2
20	314	157.0
22	380	190.0
25	491	245.5
26	531	265.4
28	616	307.8
30	707	353.4
32	804	402.1
34	908	453.9
36	1,018	509.0
40	1,256	628.3
50	1,963	981.7

The information in this literature is given as a guide only. Please refer to Ancon installation procedures, instructions and operating manuals for more specific details on these products.

Coupler Selection

The four types of Ancon reinforcing bar couplers require different fixing methods. This, together with the quantity to be fixed and the location, will determine which is the most appropriate coupler for a particular situation.

Tapered Thread

The Tapered Thread coupler is designed to suit the majority of applications which require the joining of reinforcing bars. The ends of the rebar are cut square and a tapered thread is cut onto the bar to suit the tapered thread coupler. The sleeve is tightened onto the threaded bar end using a calibrated torque wrench.

Availability of Couplers

Bar Diameter (mm)	10	12	14	16	18	20	22	24	25	26	28	30	32	34	36	40	50
Tapered Thread Standard	✓	✓	✓	✓	✓	✓	✓	✓	✓	✓	✓	✓	✓	✓	✓	✓	✓
Tapered Thread Positional	✓	✓	✓	✓	✓	✓	✓	✓	✓	✓	✓	✓	✓	✓	✓	✓	✓
Tapered Thread Transition	✓	✓	✓	✓	✓	✓	✓	✓	✓	✓	✓	✓	✓	✓	✓	✓	✓
Tapered Thread Starter Bars	✓	✓	✓	✓	✓	✓	✓	✓	✓	✓	✓	✓	✓	✓	✓	✓	✓
Tapered Thread Weldable	✓	✓	✓	✓	✓	✓	✓	✓	✓	✓	✓	✓	✓	✓	✓	✓	✓
Tapered Thread Anchor	✓	✓	✓	✓	✓	✓	✓	✓	✓	✓	✓	✓	✓	✓	✓	✓	✓
Bartec	✓	✓	✓	✓	✓	✓	✓	✓	✓	✓	✓	✓	✓	✓	✓	✓	✓
Bar X-L	✓	✓	✓	✓	✓	✓	✓	✓	✓	✓	✓	✓	✓	✓	✓	✓	✓
MBT ET	✓	✓	✓	✓	✓	✓	✓	✓	✓	✓	✓	✓	✓	✓	✓	✓	✓
MBT Transition	✓	✓	✓	✓	✓	✓	✓	✓	✓	✓	✓	✓	✓	✓	✓	✓	✓
MBT Continuity	✓	✓	✓	✓	✓	✓	✓	✓	✓	✓	✓	✓	✓	✓	✓	✓	✓
MBT Anchor	✓	✓	✓	✓	✓	✓	✓	✓	✓	✓	✓	✓	✓	✓	✓	✓	✓

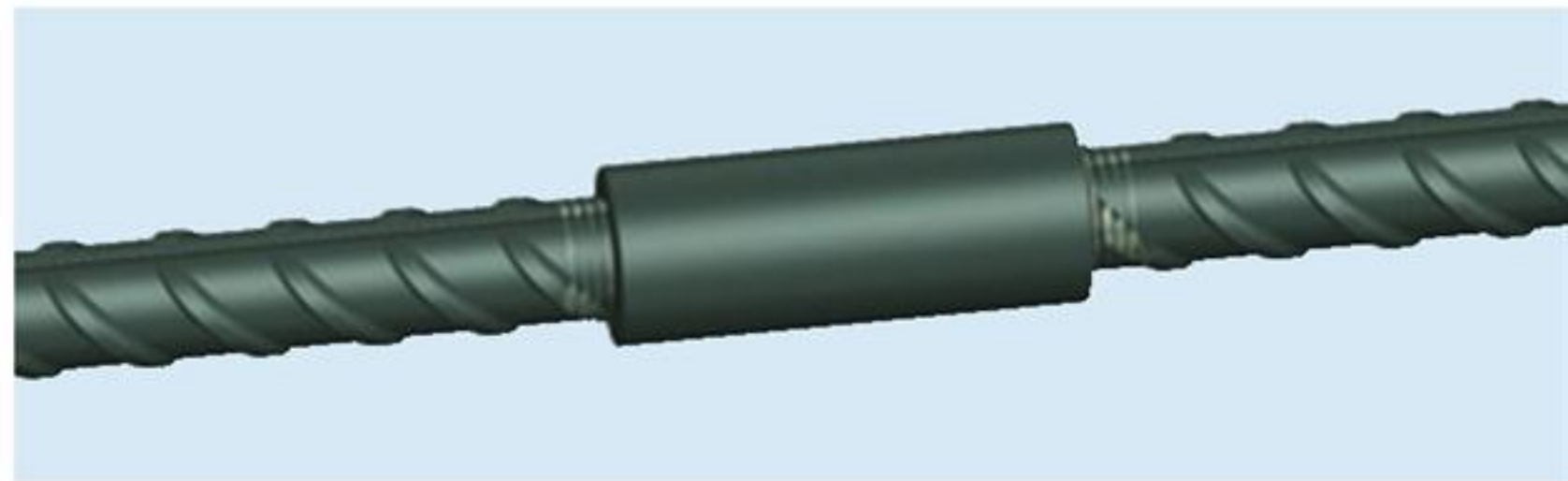

Bartec

The Bartec system is one of the smallest couplers in the Ancon range. The ends of the bars are enlarged and a parallel thread is cut onto the ends to suit the threaded coupler. The coupler is assembled using a pipe or chain wrench. Calibrated wrenches are not necessary.



Bar X-L

Bar X-L couplers provide a full strength joint and are the smallest couplers in the Ancon range. They are particularly appropriate for applications where fatigue is an issue. The ends of the bars are cut square and marginally enlarged. A parallel thread is then rolled onto the ends to suit the threaded sleeve. The coupler is installed using a pipe or chain wrench. Calibrated torque wrenches are not required. This product is only available in selected territories in mainland Europe. Please contact Ancon for locations.

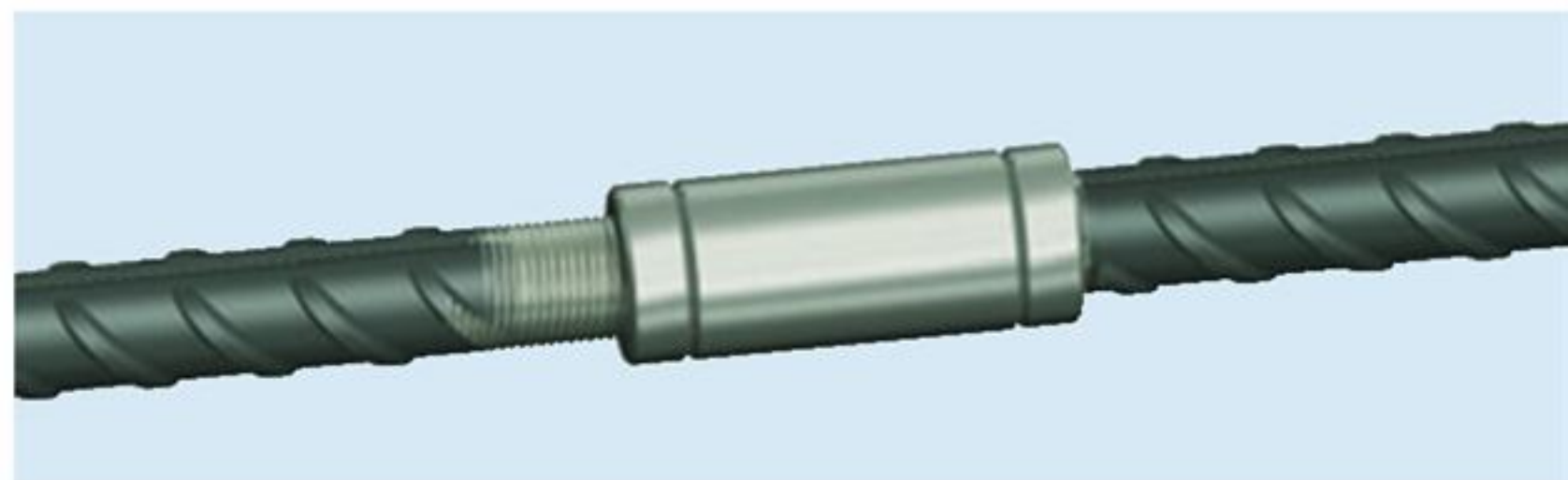

MBT

MBT couplers are suitable where it is not convenient to have the bar ends prepared for parallel thread or tapered thread couplers. The bars are supported within the coupler on two serrated saddles. Bars are locked in place by a series of special lockshear bolts, the heads of which shear off when the predetermined tightening torque is reached, providing a visual check of correct installation.

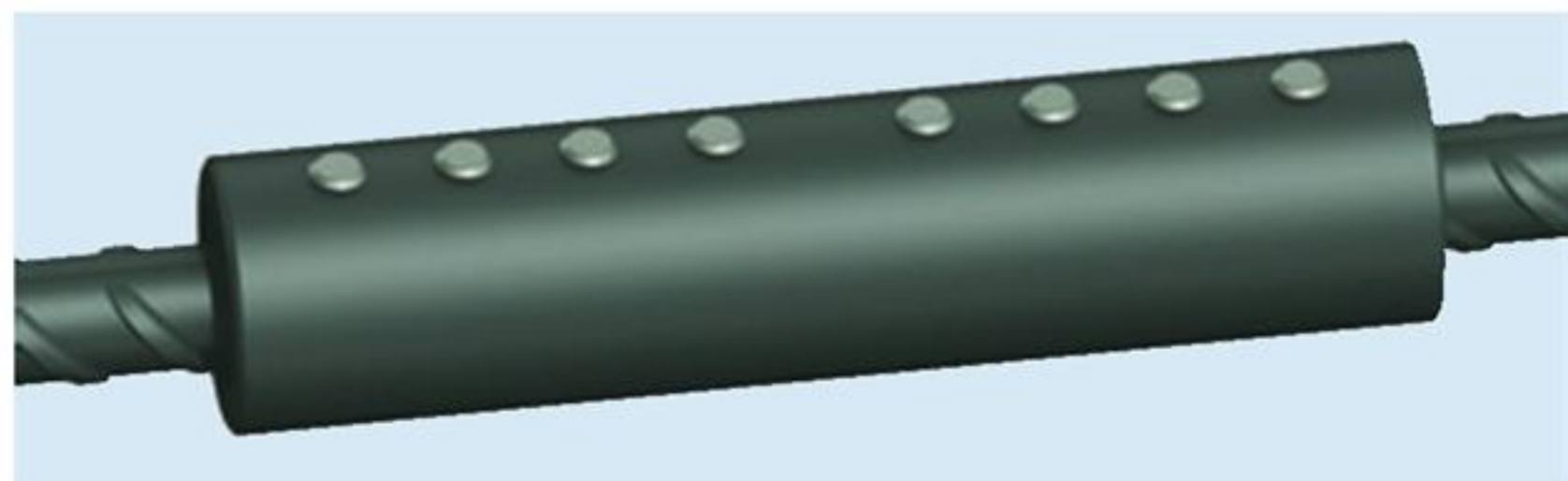

Reinforcing Bar Couplers

Coupler Selection

Range	Tapered Thread					Bartec			Bar X-L			MBT			
	Standard	Positional	Transition	Weldable	HA	Type A	Type B	Type C	Type A	Type B	Type C	ET	Transition	Continuity	HA
Bar Dia. (mm)	12-50	12-50	12-50	12-50	12-50	12-50	12-50	12-50	12-50	12-50	12-50	10-40	10-40	10-40	10-40
Bar End Prep	Threaded	Threaded	Threaded	Threaded	Threaded	Threaded	Threaded	Threaded	Threaded	Threaded	Threaded	No	No	No	No
Bar Rotation	Yes	No	Yes	Yes	Yes	Yes	Limited	No	Yes	Limited	No	No	No	No	No
Installation Method	Torque Wrench					Wrench			Wrench			Wrench or Nut Runner			
Minimum Tensile Capacity	Full Strength up to 575N/mm ²					Full Strength up to 650N/mm ²			Full Strength up to 650N/mm ²			Full Strength up to 575N/mm ²			
Approvals	BS8110 CARES TA1-B { DIBt Approval No Z-1.5-179 } { 12, 14, 16, 20, 25, 28, 32, 40 } { AFCAB Certified No M07/006 } { Sizes 12, 14, 16, 20, 25, 32, 40 }					BS8110 ACI 349 ASME III DIV 2 (ACI 359) ACI 318 CSA CAN 3 – N2872			BS8110 DET NORSE VERITAS (X-L 25, 32) ASME III DIV 2 (ACI 359) ACI 349 (36, 43, 57)			BS8110 BS5400 { BBA 98/R102 } { ET10, 12, 16, 20, 25, 32, 40 } ACI 318 DIN 1045 German Code { DIBt Approval No Z-1.5-10 } { ET 10, 12, 14, 16, 20, 25, 28 }			

Coupler Specification

Ancon Couplers can be specified using the part numbers which are included in the tabulated data in each section of this brochure.

The following examples show how each type of coupler should be specified when using 20mm bar.

Type of Coupler	Reference	Page
Tapered Thread Standard	TTS20	8
Tapered Thread Positional	TTP20	10
Tapered Thread Transition	TTT20	12
Tapered Thread Starter Bar	TTSB20	13
Tapered Thread Weldable	TTW20	14
Tapered Thread Headed Anchor	TTH20	15
Bartec Type A	BT20/A	16
Bartec Type B	BT20/B	16
Bartec Type C	BT20/C	16
Bar X-L Type A	XL20/A	20
Bar X-L Type B	XL20/B	20
Bar X-L Type C	XL20/C	20
MBT ET Series	ET20	24
MBT Transition Series	ET20/16	26
MBT Continuity Series	C20	27
MBT ET Headed Anchor	ETHA20	30

If you require any further assistance please contact Ancon Building Products.



Typical Coupler Application Guide

The following table provides a guide when selecting the most appropriate couplers for specific applications. Recommendations are based upon typical usage. Please contact Ancon for further assistance on the correct selection and specification of couplers.

Application	Tapered Thread	Bartec	Bar X-L	MBT
Wall to slab connection	✓	✓	✓	
Wall to pre-cast beam connection	✓	✓	✓	
Column construction	✓	✓	✓	✓
Extension / repairs to existing structures				✓
Pre-cast element to pre-cast element connection	✓	✓	✓	✓
Closing of access openings	✓	✓	✓	✓
Rebar cage pre-fabrication	✓	✓	✓	✓
Hook bars to pile connection				✓
Fatigue applications		✓	✓	✓
Bar end terminations	✓			✓



Reinforcing Bar Couplers

Tapered Thread

The Ancon range of Tapered Thread couplers is designed to suit the majority of applications which call for the joining of reinforcing bars. Available to suit bar sizes 12mm to 50mm, the couplers are installed quickly and easily on site without the need for specially trained personnel or specialised, expensive machinery.

The compact design of each coupler ensures suitability for use in confined situations where space is restricted or where the loss of cover must be minimised. The couplers are normally supplied fitted to the end of threaded bar, requiring only the engagement and tightening of the adjoining bar on site. In order to ensure correct installation, Ancon Building Products specifies the use of a torque wrench. The range of Tapered Thread couplers is available through major rebar suppliers. Please contact Ancon for further details.

Standard Coupler

The Standard Tapered Thread coupler is suitable for connecting two bars of the same diameter, where one bar can be rotated. It comprises an internally threaded sleeve with two right hand threads which are tapered towards the middle of the coupler. The bar ends are square cut and a tapered thread is cut onto the bar. A nominal allowance of +25mm should be allowed per threaded bar end for square cutting the bar end.

The couplers are generally torqued onto the reinforcing bar in the bar threading shop, the internal threads protected by plastic end caps. The threaded ends of the continuation bar are protected by plastic thread protectors.

Engagement of the bar within the coupler is simplified by the tapered thread design which aids alignment. When the bar is fully engaged within the coupler, the continuation bar is tightened using a torque wrench.

The Ancon Standard Tapered Thread coupler is designed for use in concrete structures to meet the requirements of BS EN 1992-1-1: 2004 (Eurocode 2) and BS 8110 for mechanical splices. They are designed to achieve failure loads in excess of 115% of the characteristic strength of grade 500 rebar.

Standard Coupler Dimensions



Bar Diameter (mm)		12	14	16	18	20	22	24	25	26	28	30	32	34	36	40	50
External Dia.	<i>d</i>	22	22	25	28	30	32	36	36	40	42	45	48	55	55	60	70
Coupler Length	<i>l</i>	58	64	70	72	74	81	87	90	94	100	106	112	119	126	138	170
Weight (kg)		0.13	0.12	0.17	0.22	0.25	0.31	0.43	0.43	0.59	0.66	0.82	0.99	1.50	1.50	1.90	2.91
Torque (Nm)		60	85	110	135	165	205	250	265	270	275	280	285	295	305	330	350
Part No.		TTS12	TTS14	TTS16	TTS18	TTS20	TTS22	TTS24	TTS25	TTS26	TTS28	TTS30	TTS32	TTS34	TTS36	TTS40	TTS50

Testing and Approvals

The Standard range of Tapered Thread couplers has been tested and approved by UK CARES to show compliance with the requirements of BS EN 1992-1-1: 2004 (Eurocode 2) and BS 8110.

The most common sizes have been tested and approved by the DIBt and are covered by Approval No Z-1.5-179.

Ancon Standard Tapered Thread Couplers, sizes 12, 14, 16, 20, 25, 32 and 40, are AFCAB Certified.

Note: Not all coupler types and sizes are relevant to the national approvals shown. For details of coupler types and sizes relevant to each national approval please refer to the relevant approval document, which is available on request.



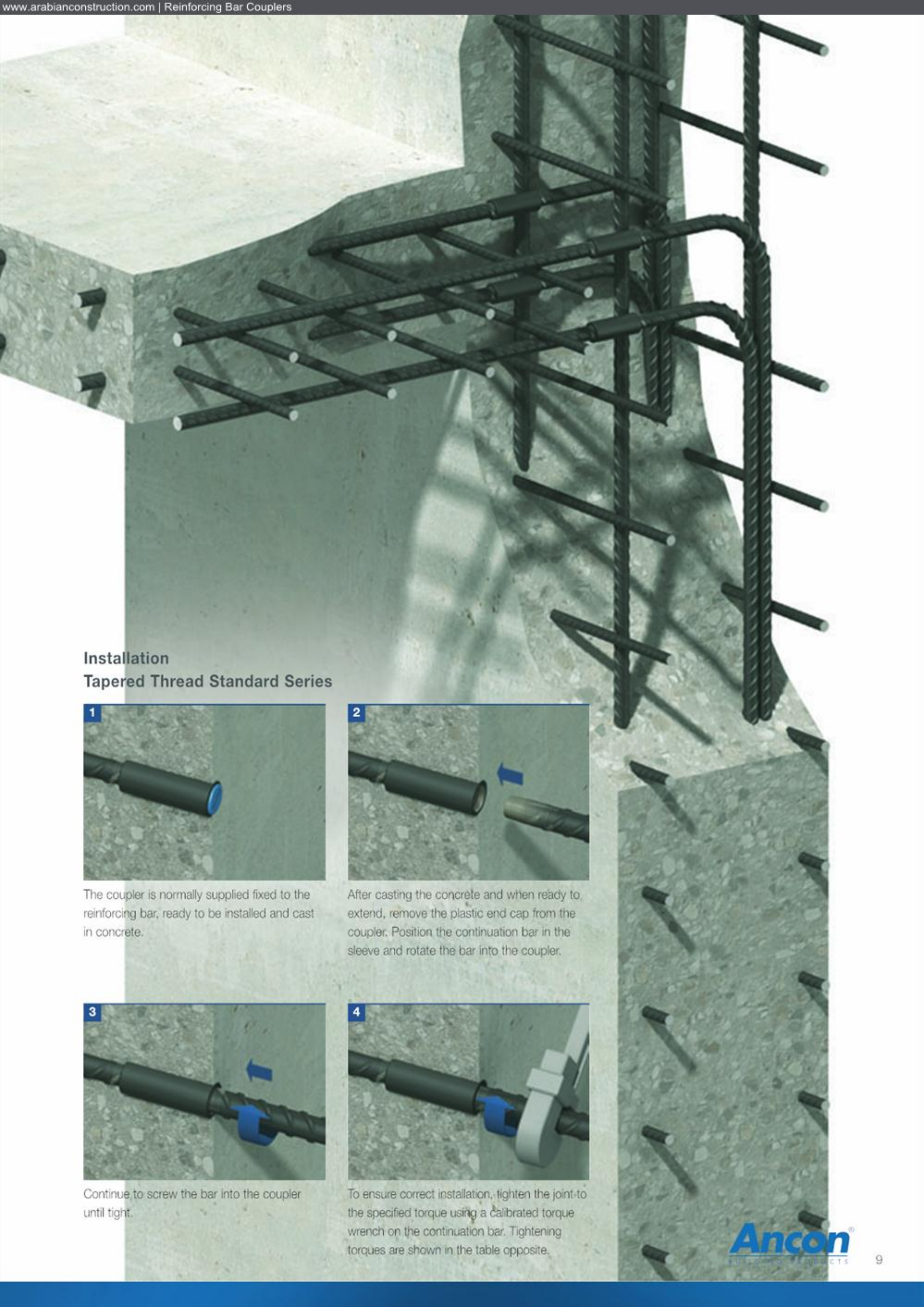

Installation Tapered Thread Standard Series



1 The coupler is normally supplied fixed to the reinforcing bar, ready to be installed and cast in concrete.



2 After casting the concrete and when ready to extend, remove the plastic end cap from the coupler. Position the continuation bar in the sleeve and rotate the bar into the coupler.

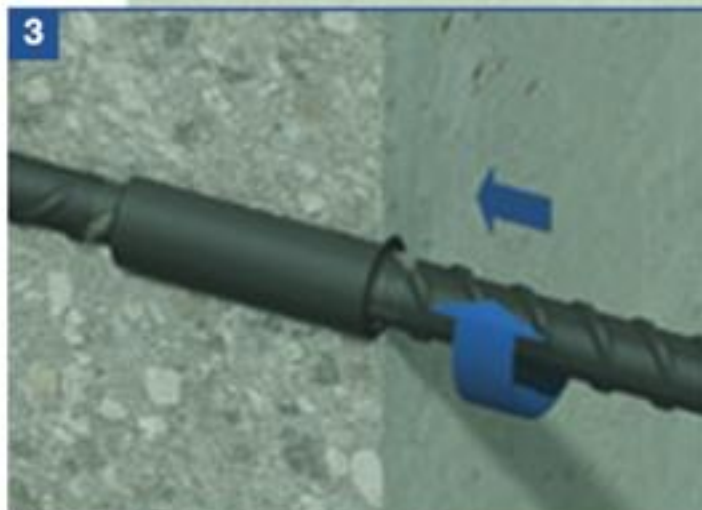

3 Continue to screw the bar into the coupler until tight.



4 To ensure correct installation, tighten the joint to the specified torque using a calibrated torque wrench on the continuation bar. Tightening torques are shown in the table opposite.

Reinforcing Bar Couplers

Positional Coupler

The Ancon Tapered Thread Positional coupler is designed to be used in applications in which neither bar can be rotated. Having a degree of adjustability, the Positional coupler can also be used as a closer between two fixed bars.

The Positional coupler comprises three components, a male section, a female section and a locking nut. The male component has an internal tapered thread and an extended external parallel thread. The female component has a parallel thread and a tapered thread, both of which are internal. A locknut is used to secure the connection when the correct degree of adjustability has been achieved. All components, including the locknut must be tightened using a torque wrench.

Plastic thread protectors are used to prevent damage to the threaded bar ends and the internal threads of the couplers are protected by plastic end caps. A nominal allowance of +25mm should be allowed per threaded bar end for square cutting the bar end.

Testing & Approvals

The Positional range of Tapered Thread couplers has been tested and approved by UK CARES to show compliance with the requirements of BS EN 1992-1-1: 2004 (Eurocode 2) and BS 8110. The most common sizes have been tested and approved by the DIBt and are covered by Approval No Z-1.5-179. Ancon Tapered Thread Positional Couplers, sizes 12, 14, 16, 20, 25, 32 and 40, are AFCAB Certified.

Note: Not all coupler types and sizes are relevant to the national approvals shown. For details of coupler types and sizes relevant to each national approval please refer to the relevant approval document, which is available on request.



Positional Coupler Dimensions

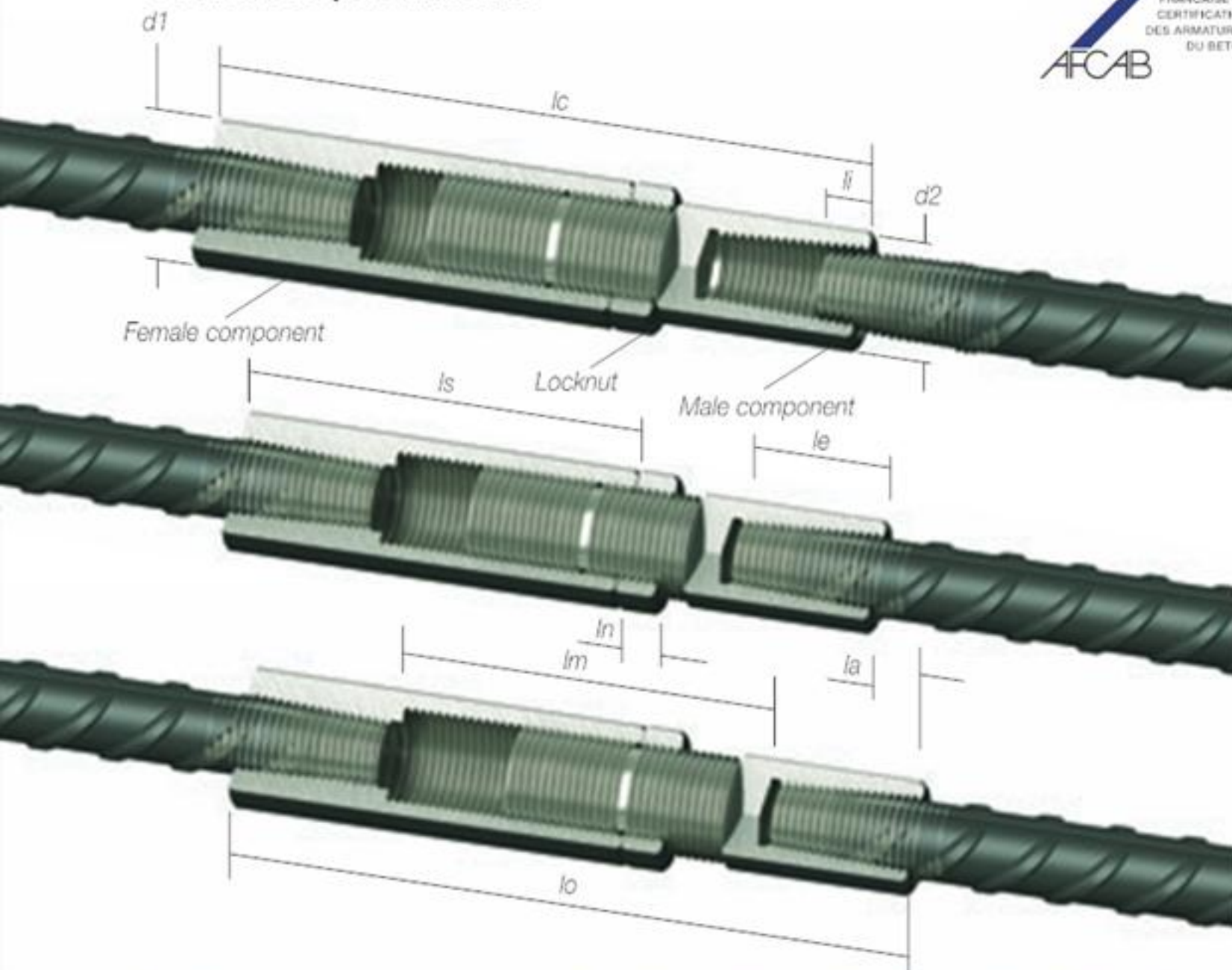

Bar Diameter (mm)		12	14	16	18	20	22	25	26	28	30	32	34	36	40	50
External Dia.	d1	25	25	30	36	36	42	48	46	50	55	55	60	70	70	85
External Dia.	d2	22	22	25	28	30	32	36	40	42	45	48	55	55	60	70
Female Sleeve Length	is	84	89	95	95	112	120	132	136	137	147	153	164	190	190	233
Locknut Length	ln	13	13	13	13	13	13	13	13	13	15	15	15	15	15	16
Closed Length	ic	138	150	155	156	180	191	207	213	218	234	243	261	296	296	359
Max. Open Length	lo	178	190	196	195	231	245	266	273	274	295	305	328	373	374	454
Bar Insertion Prior to Engagement	li	9	12	15	18	8	11	16	18	22	25	28	31	34	40	54
Bar Insertion Full Engagement	le	26	29	32	32	33	37	42	44	47	50	53	56	58	66	82
Adjustable Length	la	23	23	24	25	26	28	34	34	34	36	37	42	54	52	67
Max Distance between Bar Ends	lm	126	124	132	131	165	171	182	185	174	195	199	216	257	242	290
Weight (kg)		0.44	0.67	0.67	0.95	1.12	1.56	2.21	2.18	2.30	3.34	3.51	4.66	6.83	6.91	11.96
Coupler Torque (Nm)		60	85	110	135	165	205	265	270	275	280	285	295	305	330	350
Locknut Torque (Nm)		20	25	30	40	50	60	70	80	80	85	90	100	105	110	130
Part No.		TTP12	TTP14	TTP16	TTP18	TTP20	TTP22	TTP25	TTP26	TTS28	TTP30	TTP32	TTP34	TTP36	TTP40	TTP50

Installation

Tapered Thread Positional Series



The female section of the positional coupler is normally cast flush in the concrete. The installer must take care to protect the internal threads and prevent the ingress of concrete. Once cast and ready to extend, the male end complete with locknut can be screwed into place.



Position the continuation bar as near as possible to the coupler fitted to the cast-in bar.



Run the male component and locknut onto the continuation bar until fully engaged.



Using a torque wrench tighten the male component on the continuation bar to the specified torque, whilst holding the continuation bar with a second wrench.



Run the locknut along the threaded barrel of the male component to abut the female section. Using the torque wrench, tighten the locknut to the specified torque. Tightening torques are shown in the table opposite.

At this point the groove in the parallel threaded section of the male component must be completely covered by the locknut. If any part of the groove is visible beyond the locknut, the degree of adjustability has been exceeded and the installation is incorrect.

Correct Installation



Groove is completely hidden within locknut

Incorrect Installation



Groove is protruding from locknut



Reinforcing Bar Couplers



Transition Coupler

The Ancon Tapered Thread Transition coupler is used to join reinforcing bars of different diameters where one coupler can be rotated.

With all the benefits of the Standard range, Transition couplers are designed to achieve failure loads greater than 115% of the characteristic strength of the smaller diameter grade 500 reinforcing bar. The Transition coupler comprises an internally threaded sleeve with two right hand threads both of which are tapered towards the middle of the coupler.

The diameter of each thread corresponds to the appropriate bar size. A nominal +25mm should be allowed per threaded bar end for square cutting the bar end.

Testing & Approvals

The Transition range of Tapered Thread couplers has been tested and approved by UK CARES to show compliance with the requirements of BS EN 1992-1-1: 2004 (Eurocode 2) and BS 8110.



Tapered Thread Transition couplers have also been approved up to size 32/40 by the DIBt and are covered by Approval No Z-1.5-179.



Ancon Tapered Thread Transition couplers, sizes 12/14, 12/16, 14/16, 16/20, 20/25, 25/32 and 32/40, are AFCAB certified.

Note: Not all coupler types and sizes are relevant to the national approvals shown. For details of coupler types and sizes relevant to each national approval please refer to the relevant approval document, which is available on request.

Installation

Tapered Thread Transition Series

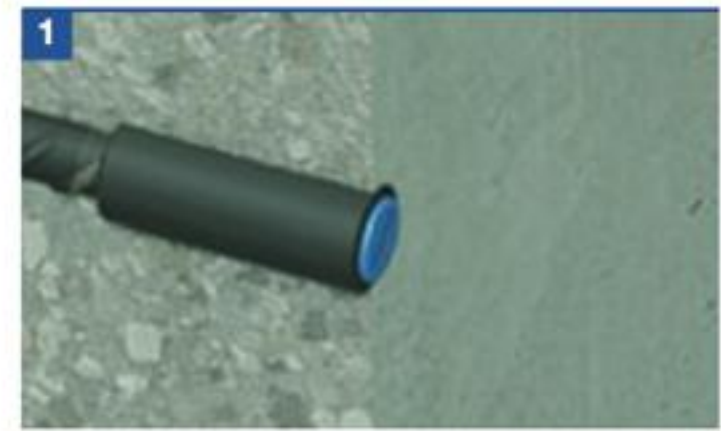

The coupler is normally supplied fixed to a reinforcing bar, ready to be installed and cast in concrete.

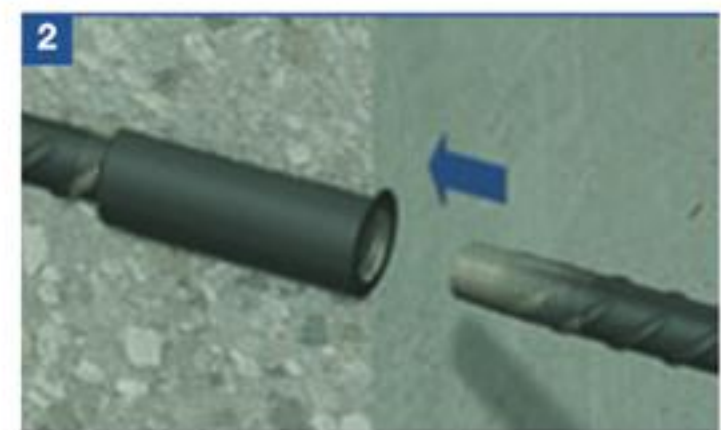

After casting of the concrete and when ready to extend, remove the plastic end cap from the coupler. Position the continuation bar in the sleeve and rotate the bar into the coupler.

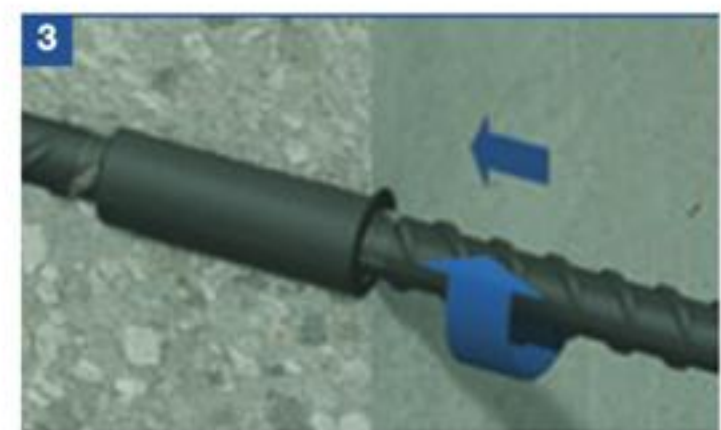

Continue to screw the bar into the coupler until tight.



To ensure correct installation, tighten the joint to the specified torque using a calibrated torque wrench on the continuation bar. Tightening torques are shown in the table below.

Note: In the event of the coupler being supplied fixed to the smaller bar it is necessary to ensure that when tightening the larger continuation bar, the force is not transmitted through the smaller bar.

Transition Coupler Dimensions



Bar Diameter	12/14	12/16	14/16	16/18	16/20	18/20	20/22	20/25	20/28	22/26	25/28	25/32	26/30	28/32	30/34	32/40	34/40	40/50
External Dia. <i>d</i>	22	25	25	28	30	30	32	36	42	40	42	48	45	48	55	55	60	70
Coupler Length <i>l</i>	65	72	71	75	78	77	82	90	91	92	99	112	104	110	117	138	133	170
Weight (kg)	0.14	0.21	0.19	0.25	0.30	0.28	0.32	0.48	0.65	0.62	0.72	1.11	0.87	1.02	1.59	1.62	1.97	3.31
Torque (Nm)	60/85	60/110	85/110	110/135	110/165	135/165	165/205	165/265	165/275	205/270	265/275	265/285	270/280	275/285	280/295	285/330	295/330	330/350
Part No.	TTT12/14	TTT12/16	TTT14/16	TTT16/18	TTT16/20	TTT18/20	TTT20/22	TTT20/25	TTT20/28	TTT22/26	TTT25/28	TTT25/32	TTT26/30	TTT28/32	TTT30/34	TTT32/40	TTT34/40	TTT40/50

Starter Bar System

The Ancon Starter Bar system is designed to increase the speed of construction by eliminating the need to cut or drill formwork at construction joints where continuity of reinforcement is required.

Incorporating the Ancon tapered thread coupler, approved by UK CARES, the system simplifies design and is ideal for use with slipforming.

The starter bar system comprises two elements. The female section consists of a threaded bar connected to a tapered thread coupler. A nail plate is fixed to the end of the coupler and is held in place by a plastic end cap. This prevents ingress of concrete until the continuation bar is fixed. The male section comprises a straight bar threaded at one end to allow connection to the coupler after striking the formwork and removing the end cap and nail plate. In order to ensure correct installation the continuation bar is tightened using a calibrated torque wrench.

Installation

The coupler is normally supplied fixed to the reinforcing bar. Upon removal of the plastic end cap, position the nail plate, which is supplied separately, on the end of the coupler to enable it to be fixed flush to the formwork. Secure the nail plate by replacing the end cap. Tie the starter bar assembly to the fixed bar and position against the formwork. Nail the assembly to the formwork.

After casting the concrete and striking the formwork, remove the end cap and nail plate and place the continuation bar in the coupler and rotate until tight. To ensure correct installation tighten the rebar to the specified torque using a calibrated wrench on the continuation bar. Tightening torques are shown in the following tables.

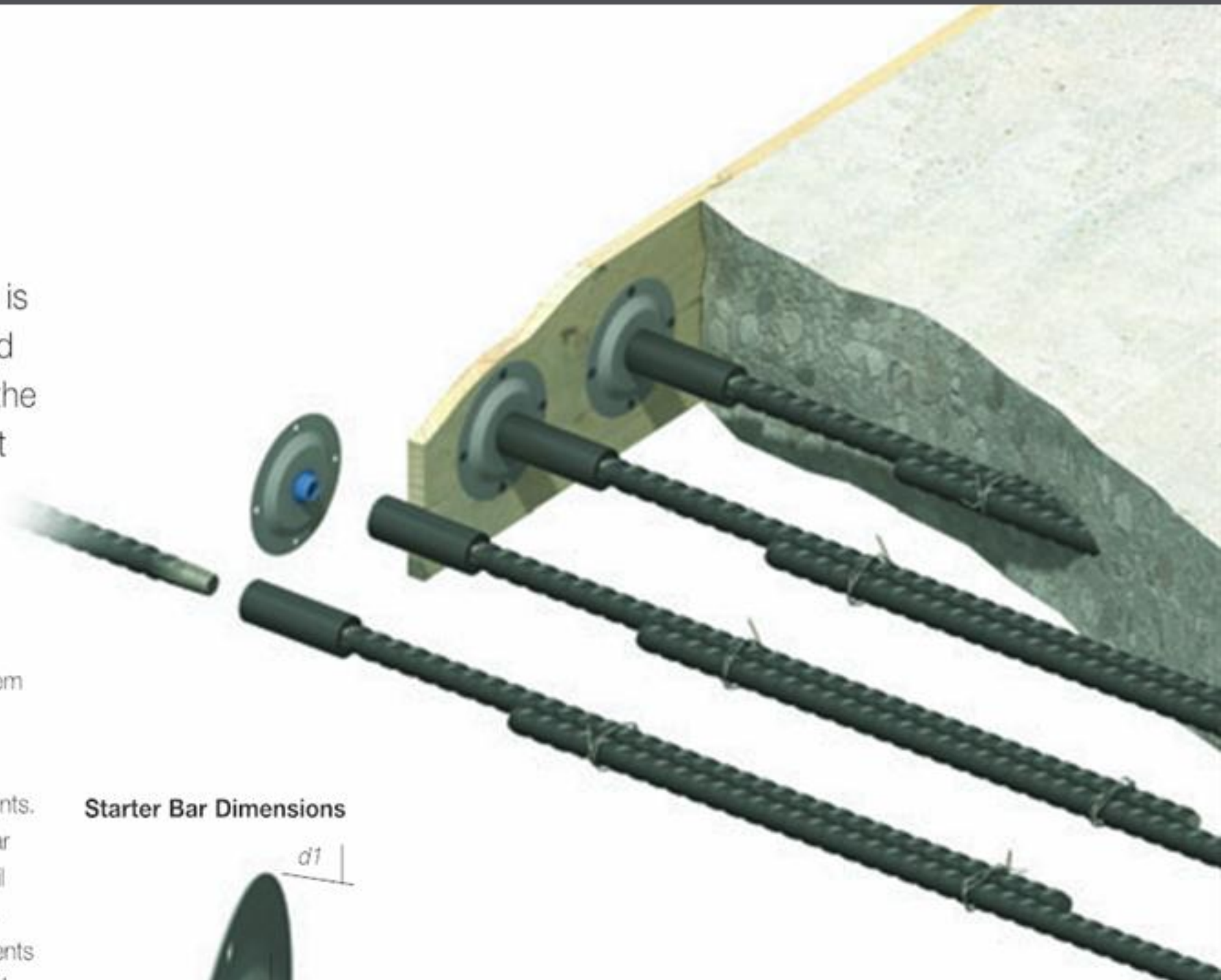

Starter Bar Dimensions

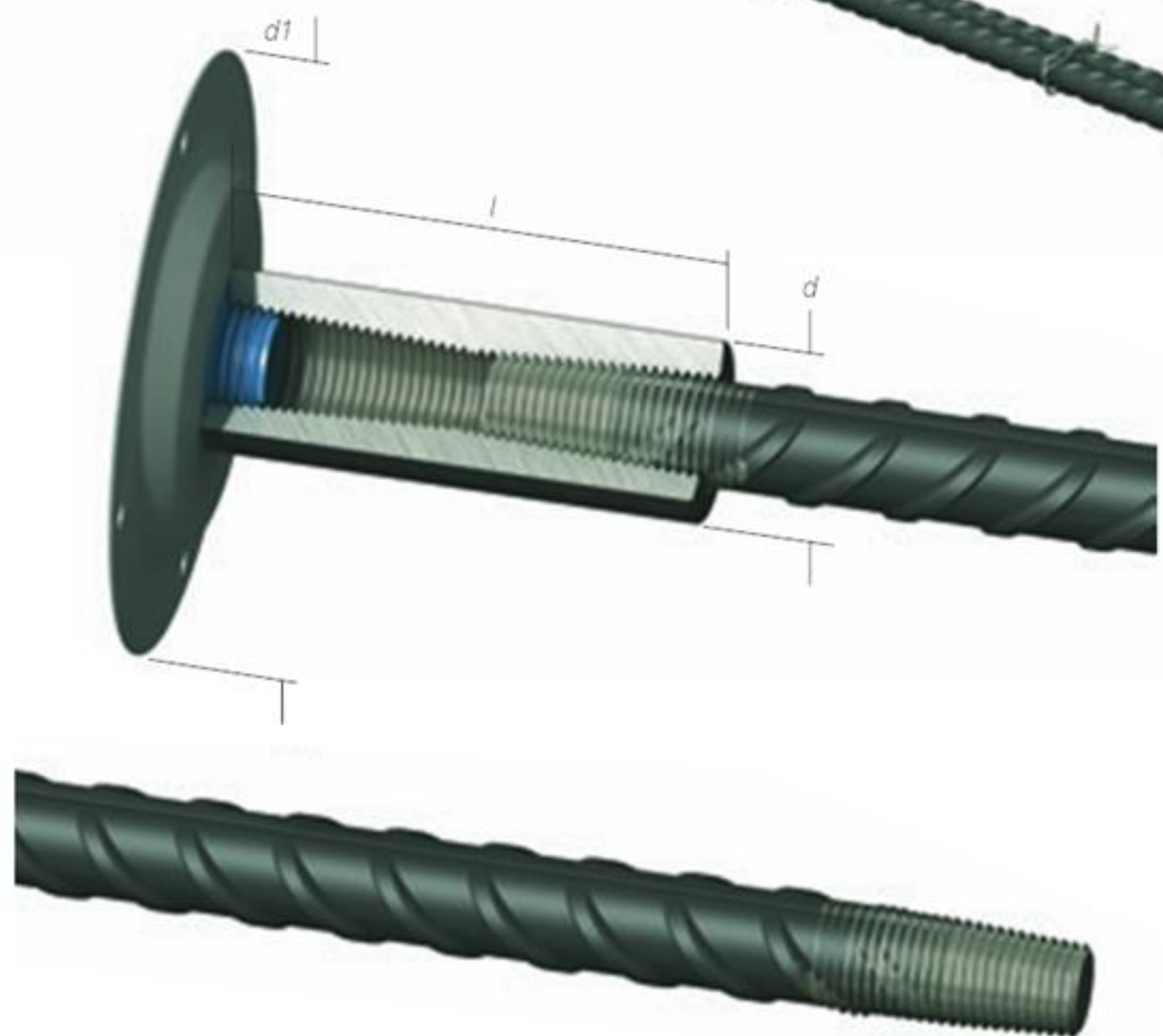

Threaded Continuation Bar

Bar Diameter	12	14	16	18	20	22	24	25	32
Bar Length	625	730	830	935	1035	1140	1240	1290	1655
Torque (Nm)	60	85	110	135	165	205	250	265	285
Part No.	TTSB12M	TTSB14M	TTSB16M	TTSB18M	TTSB20M	TTSB22M	TTSB24M	TTSB25M	TTSB32M

The threaded bar lengths in the table above are minimum lap lengths. Longer bars are available upon request.

Starter Bar

Bar Diameter	12	14	16	18	20	22	24	25	32
System Length (Bar with coupler)	660	765	870	975	1075	1185	1285	1340	1715
Coupler Length	<i>l</i>	58	64	70	72	74	81	87	112
Coupler External Dia.	<i>d</i>	22	22	25	28	30	32	36	48
Nail Plate Dia.	<i>d1</i>	70	70	70	70	70	90	90	90
Torque (Nm)	60	85	110	135	165	205	250	265	285
Part No.	TTSB12F	TTSB14F	TTSB16F	TTSB18F	TTSB20F	TTSB22F	TTSB24F	TTSB25F	TTSB32F

The threaded bar lengths in the table above are minimum lap lengths. Longer bars are available upon request.

Reinforcing Bar Couplers

Tapered Thread Weldable Couplers

Ancon Tapered Thread Weldable couplers provide a convenient means of connecting reinforcing bars to structural steel plates or sections.

Shorter than the standard coupler, it has a tapered thread at one end. The other end is welded directly to the steel. The couplers are produced in either steel grade Type 1045 to ASTM A576 or Type 150M19 steel to BS970.

The Tapered Thread Weldable coupler is suitable for welding to structural steels, Grade S275 or Grade S355. The load conditions at the connection must be determined by the designer along with the type and size of weld required. Another important consideration is the type of electrode to be used, which must be matched to the properties of the plate and tube, and to the site conditions under which the welding will be undertaken. Welders should be qualified for the type of weld required.

For further assistance and technical information please contact Ancon Building Products.

Testing & Approvals

The most common sizes of Tapered Thread Weldable couplers have been tested and approved by the DIBt and are covered by Approval No Z-1.5-179.

Ancon Tapered Thread Weldable Couplers, sizes 12, 14, 16, 20, 25, 32 and 40, are AFCAB Certified.

Note: Not all coupler types and sizes are relevant to the national approvals shown. For details of coupler types and sizes relevant to each national approval please refer to the relevant approval document, which is available on request.

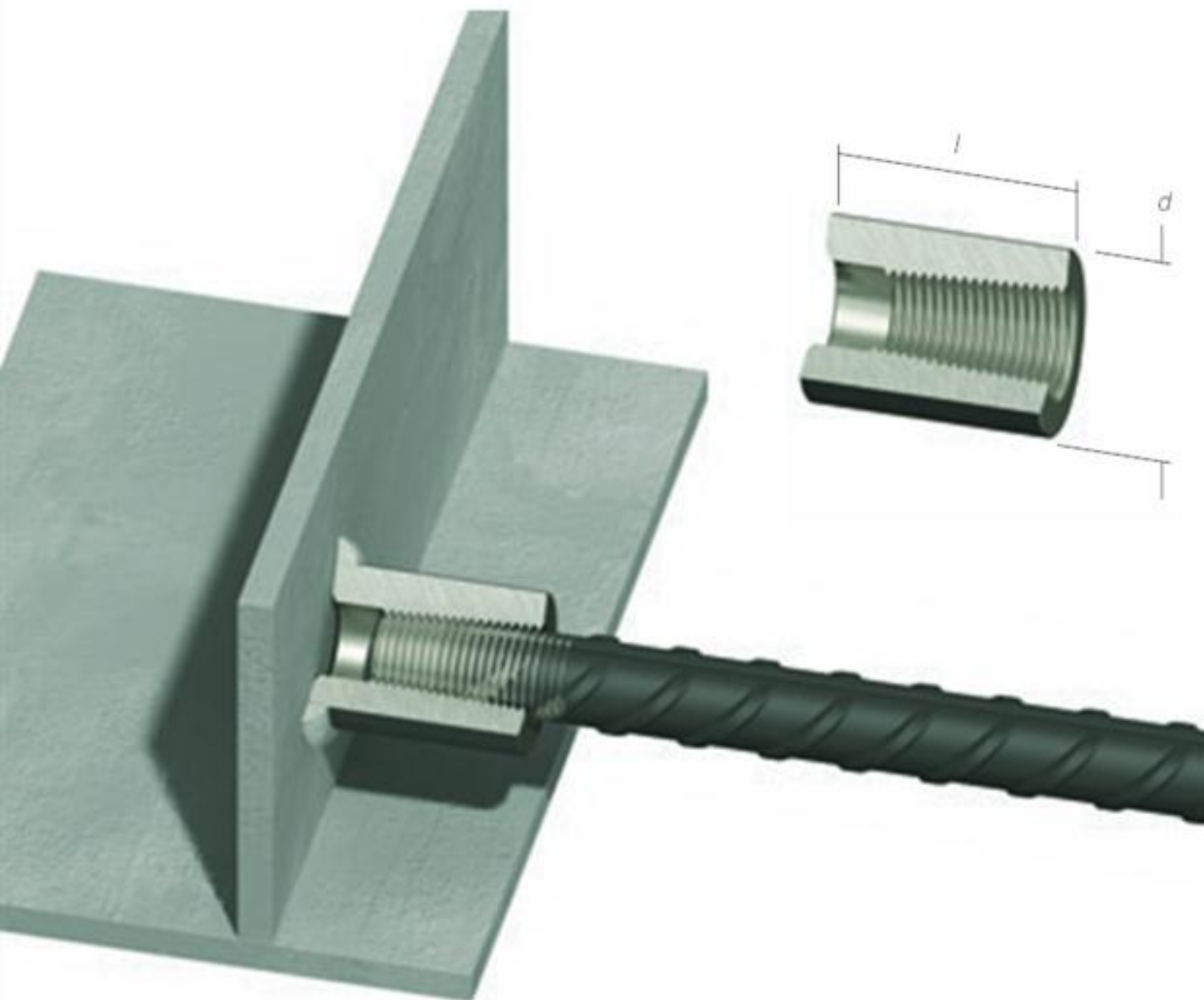

Installation

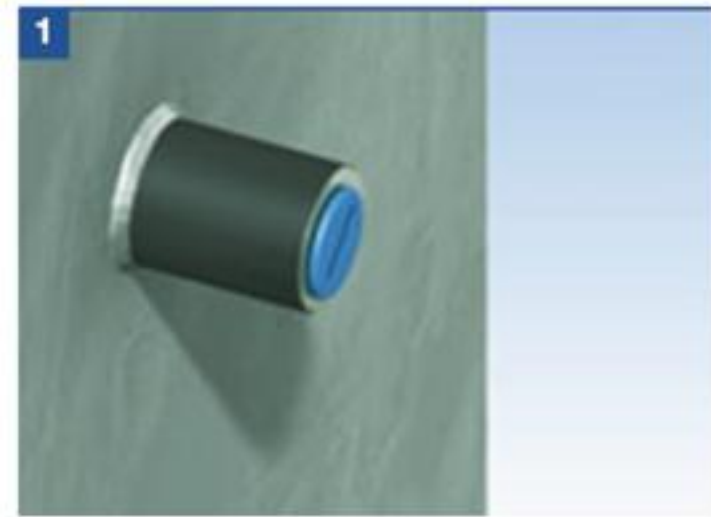

The coupler must first be welded to the steelwork.

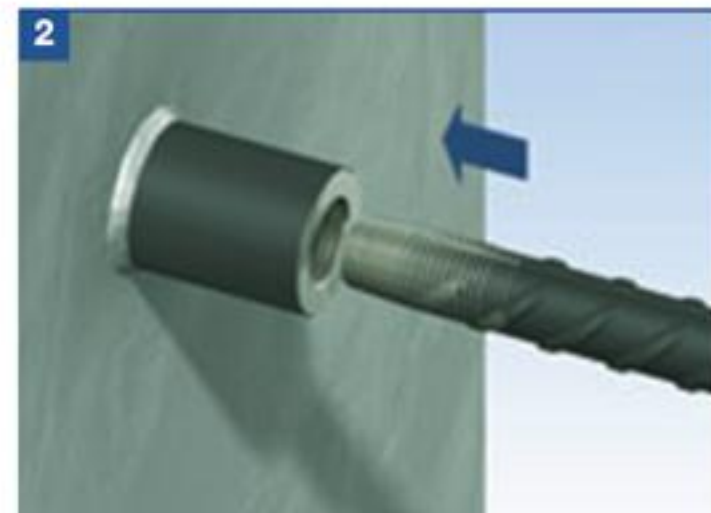

When ready to extend, remove the plastic end cap and position the continuation bar into the sleeve.

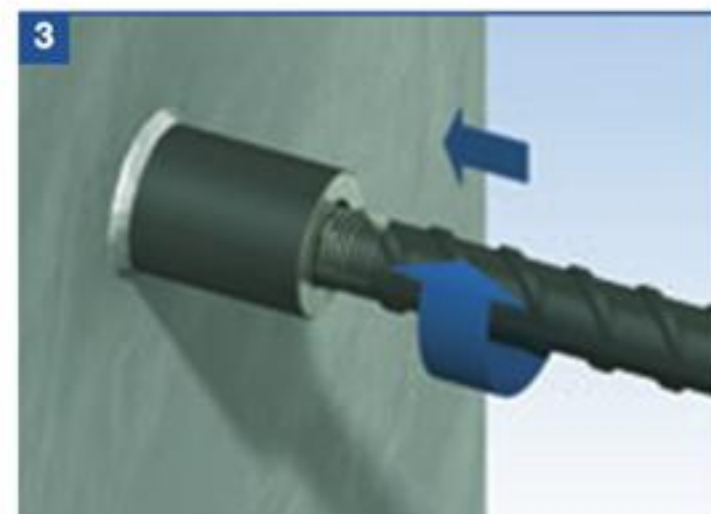

Rotate the bar into the coupler until tight.



To ensure correct installation, tighten the joint to the specified torque using a calibrated torque wrench on the continuation bar. Tightening torques are shown in the table below.

Weldable Coupler Dimensions

Bar Diameter		12	14	16	18	20	22	25	26	28	30	32	34	40	50
External Dia.	<i>d</i>	25	30	30	32	36	40	48	50	50	55	55	60	70	85
Coupler Length	<i>l</i>	35	38	42	44	47	52	57	60	63	69	72	78	89	110
Weight (kg)		0.11	0.17	0.18	0.20	0.28	0.38	0.63	0.72	0.72	0.97	0.97	1.28	1.97	3.51
Torque (Nm)		60	85	110	135	165	205	265	270	275	280	285	295	330	350
Part No.		TTW12	TTW14	TTW16	TTW18	TTW20	TTW22	TTW25	TTW26	TTW28	TTW30	TTW32	TTW34	TTW40	TTW50

Tapered Thread Headed Anchors

The Tapered Thread Headed Anchor provides an alternative method of achieving rebar end anchorage within concrete.

Anchorage of rebars within a concrete section is traditionally achieved by means of creating a long hooked end on the rebar. This can lead to problems when positioning the bar and can increase congestion. It can ultimately result in larger than necessary concrete sections at the location of the hooked ends.

Consisting of an oversized coupler, the Tapered Thread Headed Anchor carries the full tension load of the bar when it is bearing against the concrete. The Headed Anchor removes the need for hooked rebar and subsequently reduces congestion and simplifies bar placement. This in turn increases speed of construction and gives greater flexibility in design. Typical applications include pile caps and beam to column connections.

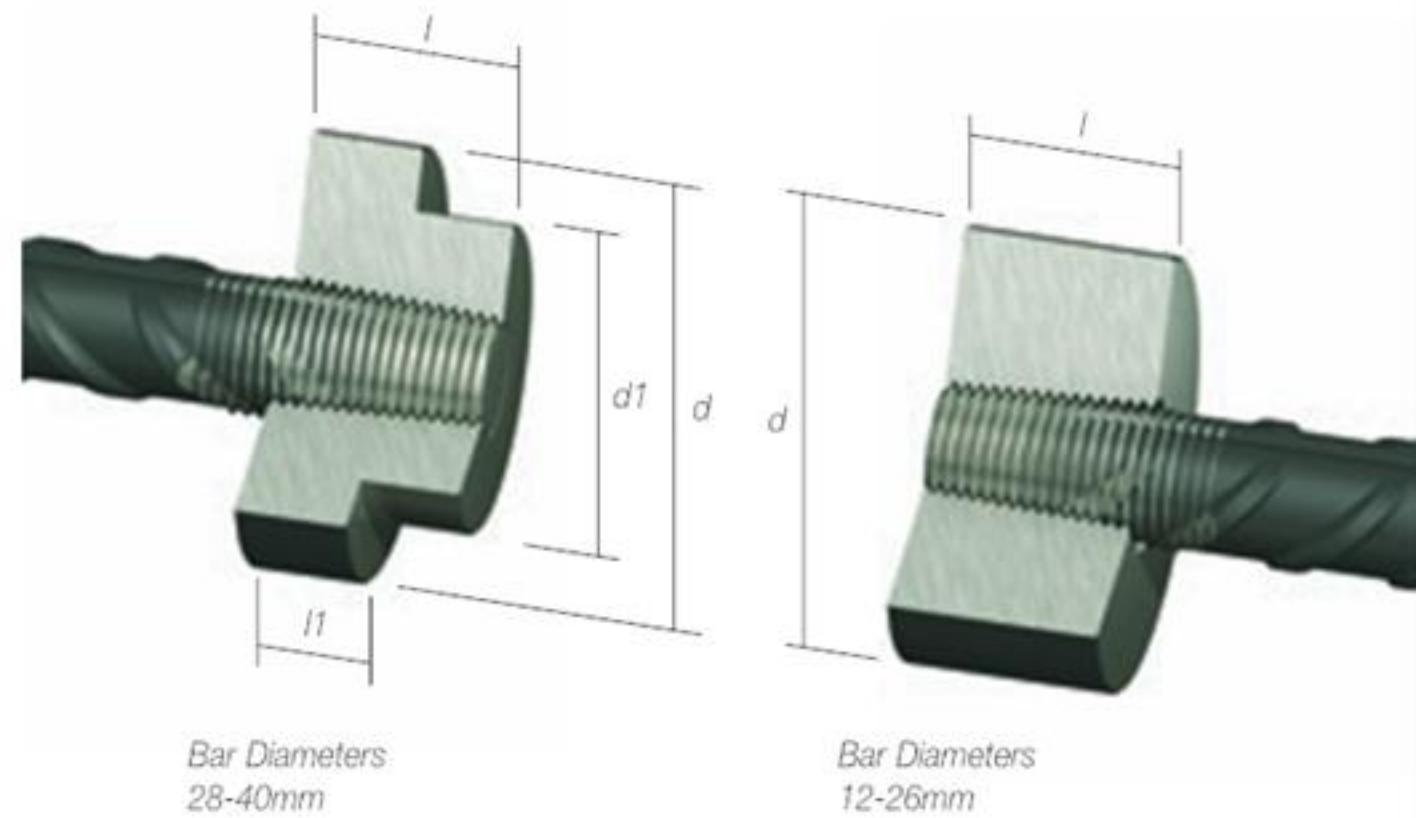

Tapered Thread Headed Anchor Dimensions

Bar Diameter		12	14	16	18	20	22	24	25	26	28	30	32	34	36	40
External Dia.	<i>d</i>	40	45	50	55	65	70	80	80	85	90	100	110	115	120	135
External Dia.	<i>d1</i>	-	-	-	-	-	-	-	-	-	78	78	78	78	78	78
Coupler Length	<i>l</i>	27.0	30.0	33.0	35.0	35.0	38.5	42.5	43.5	45.0	46.5	50.0	53.5	56.0	60.5	67.5
Coupler Length	<i>l1</i>	-	-	-	-	-	-	-	-	-	21.5	25.0	28.5	30.0	35.5	42.5
Weight (kg)		0.25	0.34	0.46	0.61	0.83	1.06	1.54	1.57	1.84	1.86	2.23	2.81	3.11	3.62	5.17
Torque (Nm)		60	85	110	135	165	205	250	265	270	275	280	285	295	305	330
Part No.		TTH12	TTH14	TTH16	TTH18	TTH20	TTH22	TTH24	TTH25	TTH26	TTH28	TTH30	TTH32	TTH34	TTH36	TTH40

Note: Where tapered thread headed anchors are used, the compressive strength of the concrete shall not be less than strength grade C32/40 (cylinder/cube).

Testing & Approvals

The most common sizes of Headed Anchors have been tested and approved by the DIBt and are covered by Approval No Z-1.5-179.



Ancon Headed Anchors, sizes 12, 14, 16, 20, 25, 32 and 40, are AFCAB Certified.



Note: Not all coupler types and sizes are relevant to the national approvals shown. For details of coupler types and sizes relevant to each national approval please refer to the relevant approval document, which is available on request.

Accessories

Threading Machine

The Ancon threading machine provides a fast, simple and reliable threading operation. The machine is compact, making it completely portable and easy to locate. It is of a robust design to provide a long, low maintenance life.

Threading machines are generally located in stockists' yards. For larger projects Ancon machines can be made available for hire. Please contact Ancon for further information.

Training on the correct usage of the threading machine is provided by Ancon technicians.

Machine Consumables

The following consumables are available:

Chaser Sets

Chaser sets are available on a regrindable or disposable basis. Each set can be reground up to 3 times in order to extend cutting life. Please contact Ancon Building Products for details.

Coolant

Ancon Building Products recommends the use of Solmaster EPS or a similar water based coolant.

Thread Protectors

Plastic sleeves are available to protect the tapered threads on reinforcing bars.

Torque Wrenches

In order to ensure the correct assembly of tapered thread couplers the use of a calibrated torque wrench is essential. Details of wrenches are included in the table below. Each wrench is supplied with a certificate of calibration.

Torque Wrench Calibration

A calibration service for wrenches purchased from Ancon is available. Please contact Ancon for further details.



Torque Wrench

Torque Wrenches

Torque Wrenches for Couplers and Locknuts

Part No.	E879008	E879009	E879010
Torque (Nm)	60 - 285	85 - 350	20 - 90

Torque Values (Nm)

Bar Diameter	12	14	16	18	20	22	24	25	26	28	30	32	34	36	40	50
Standard Coupler	60	85	110	135	165	205	250	265	270	275	280	285	295	305	330	350
Positional Coupler	60	85	110	135	165	205	250	265	270	275	280	285	295	305	330	350
Positional Locknut	20	25	30	40	50	60	65	70	80	80	85	90	100	105	110	130

Bar Diameter	12/14	12/16	14/16	16/18	16/20	18/20	20/22	20/25	20/28	22/26	25/28	25/32	26/30	28/32	30/34	32/40	34/40	40/50
Transition Coupler	60/85	60/110	85/110	110/135	110/165	135/165	165/205	165/265	165/275	205/270	265/275	265/285	270/280	275/285	280/295	285/330	295/330	330/350

Reinforcing Bar Couplers

Bartec

Bartec couplers produce a full strength joint yet they are among the smallest in the Ancon range, best suited to large scale projects requiring a high volume of couplers.



The end of each bar to be joined is cut square and enlarged by cold forging. This increases the core diameter of the bar to ensure that the joint is stronger than the bar.

Parallel metric threads are cut onto the enlarged ends. The threaded end is then proof tested to a force equal to the characteristic yield strength of the bar. A nominal allowance of +50mm per threaded bar end should be made for cutting square and cold forging.

The threaded ends of the bars are protected by an external plastic sheath. Couplers, which are usually supplied attached to the bar, have their internal threads protected by an internal plastic end cap. For certain applications, especially where Bartec is being used in deep pours,

the coupler end caps may not prevent the ingress of concrete fines. For these applications, further protection may be required.

Bartec couplers are also available to join bars of different diameters. For further information please contact Ancon Building Products.



Bartec Dimensions

Bar Diameter		12	16	20	25	28	32	36	40	50
External Dia.	d	21	26	32	40	45	50	57	62	77
Coupler Length	l	32	40	48	60	66	72	84	90	112
Thread Size		M16	M20	M24	M30	M33	M36	M42	M45	M56
Thread Pitch		2.0	2.5	3.0	3.5	3.5	3.0/4.0*	4.5	4.5	5.5
Weight (kg)		0.04	0.09	0.16	0.32	0.43	0.58	0.87	1.13	2.17
Part No Type A		BT12/A	BT16/A	BT20/A	BT25/A	BT28/A	BT32/A	BT36/A	BT40/A	BT50/A
Part No Type B		BT12/B	BT16/B	BT20/B	BT25/B	BT28/B	BT32/B	BT36/B	BT40/B	BT50/B
Part No Type C		-	BT16/C	BT20/C	BT25/C	BT28/C	BT32/C	BT36/C	BT40/C	BT50/C

*Dependent on geographical location. Please contact Ancon for further details.

Bartec Type A

The Bartec Type A system utilises internally threaded couplers with a single right hand thread and is suitable for applications where the continuation bar can be rotated. The ends of the bars are upset and threaded for half the length of the coupler.

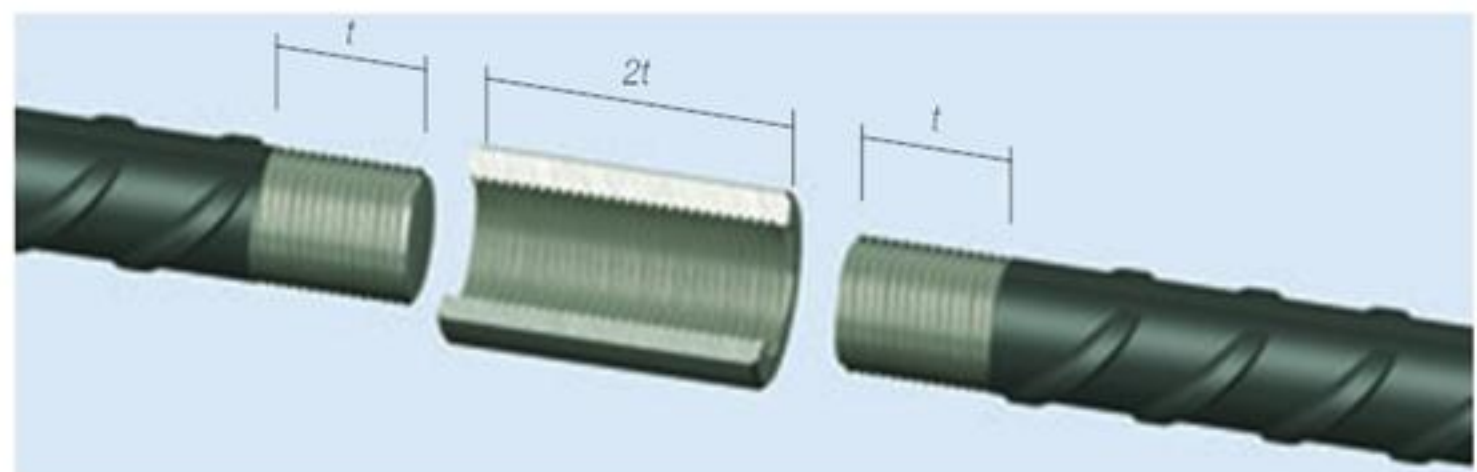

Bartec Type B

The Bartec Type B uses the same coupler as the Type A system, but one bar is threaded for a full coupler length. It is used for applications where it is difficult but not impossible to rotate the continuation bar.

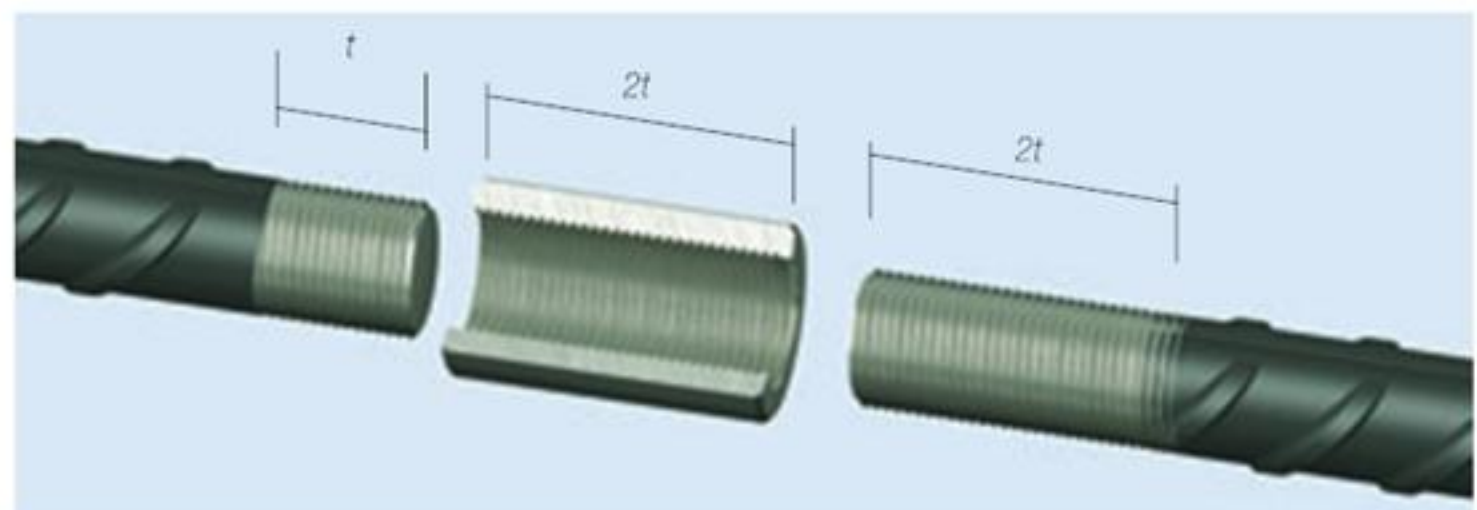

Bartec Type C

The Bartec Type C system has an additional locknut and is used where the continuation bar cannot be rotated. The continuation bar is threaded for the full coupler length plus the length of the locknut.

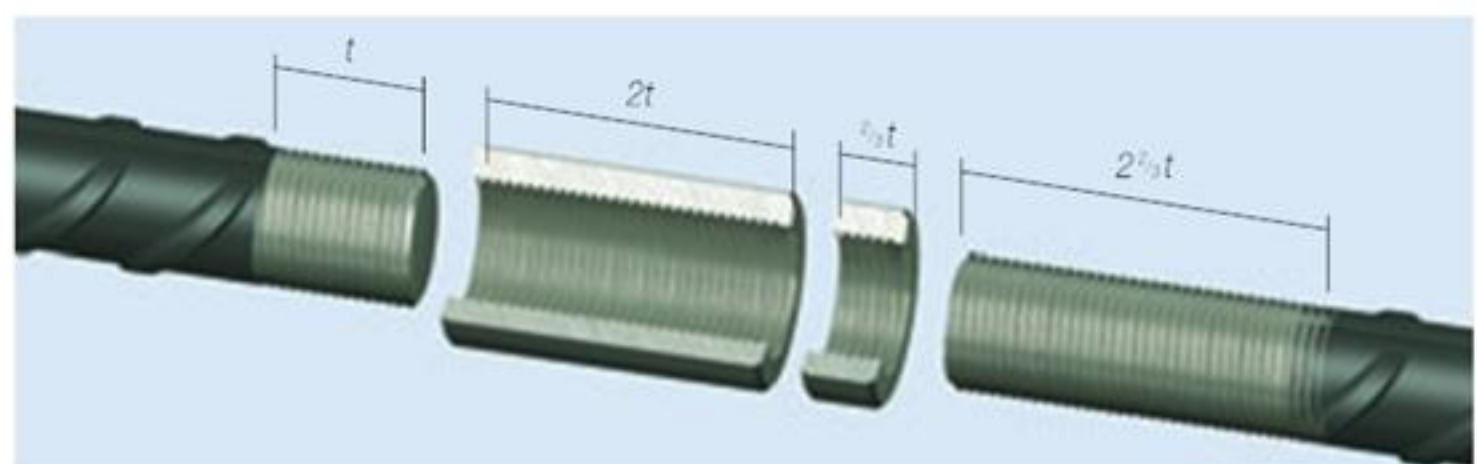

Two Stage Construction

In two stage construction utilising Types B and C couplers, it is essential to form a pocket in the face of the first stage concrete. This will create the space for the coupler to run onto the thread of the fixed reinforcing bar.

A pocket former is screwed onto the end of the bar and cast flush with the face of the concrete.

Mobile Bar End Preparation Facility

Bartec threading equipment is generally established in the rebar supplier's premises and couplers are usually supplied pre-fixed to the threaded bar ends.

On large contracts where bar end preparation can be carried out on site, equipment can be made available for hire. It should be noted that the hirer will need to provide sufficient power, air, rebar support tressles and crane handling facilities.



Testing & Approvals

Bartec couplers are designed and manufactured in accordance with BS EN ISO 9001 and comply in all respects to BS EN 1992-1-1: 2004 (Eurocode 2) and BS 8110 when used with reinforcing bar to BS 4449. Full destructive tests have been carried out to show compliance with the following codes: ACI 349; ASME III DIV 2 (ACI 359); ACI 318; CSA CAN 3 - N2872.

Typical Test Results

Nominal Bar Size Dia. mm	Yield Stress (N/mm ²)	Ultimate Stress (N/mm ²)	Elongation %	Failure Mode
16	531	597	18	Bar Break
20	518	596	20	Bar Break
25	522	625	18	Bar Break
32	484	604	20	Bar Break
40	512	629	18	Bar Break
50	510	669	17	Bar Break



Reinforcing Bar Couplers

Installation

The Bartec Type A System

1
Screw the coupler to the rear of the thread on the fixed bar and lock tight. The bar end should be central within the coupler.

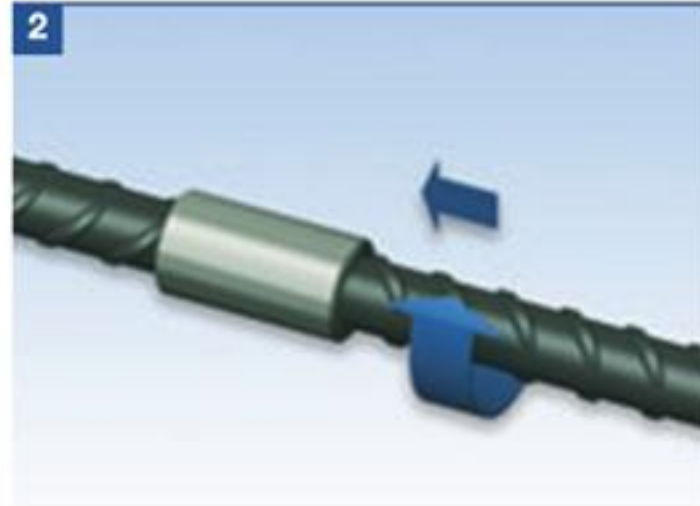
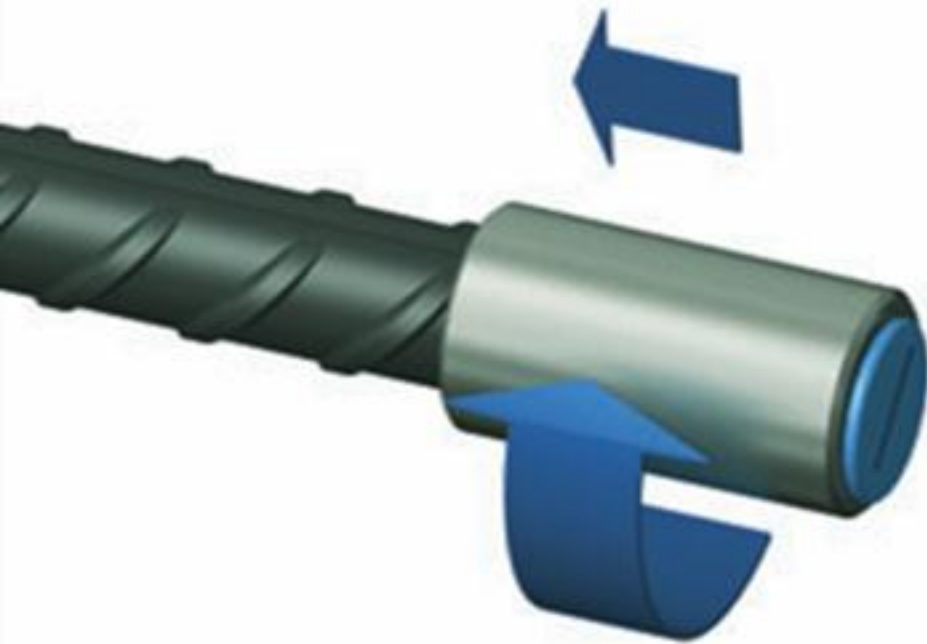

2
Remove the plastic cap from the coupler. Position and rotate the continuation bar in the coupler.



3
Tighten the joint using a wrench on the continuation bar. After tightening there should be no more than 2-4mm of thread exposed, depending on the diameter of the rebar.



The Bartec Type B System

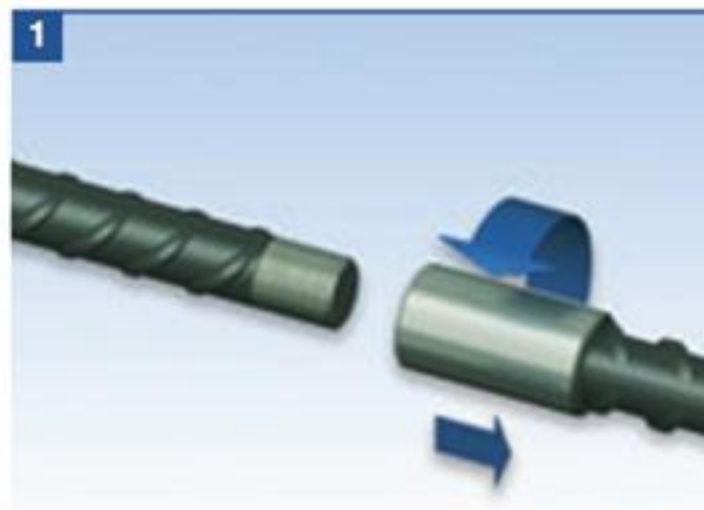

1
Screw the coupler to the rear of the thread on the continuation bar.

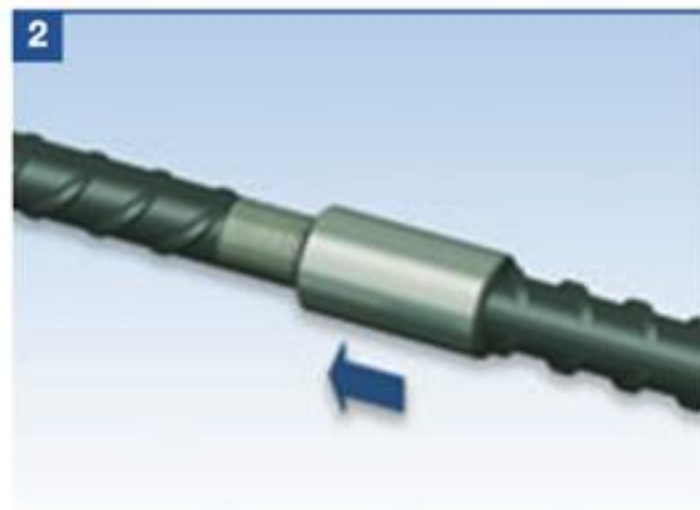

2
Position the continuation bar with the coupler against the end of the first bar.

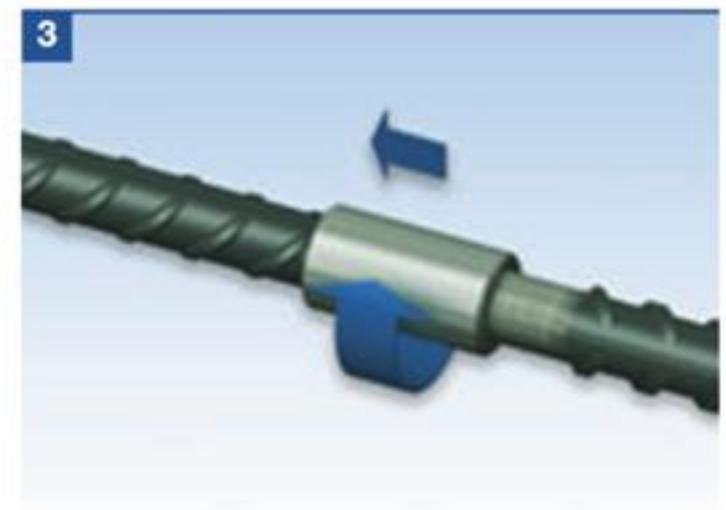

3
Rotate the coupler from the continuation bar to engage against the rear of the thread on the opposing bar and lock tight.

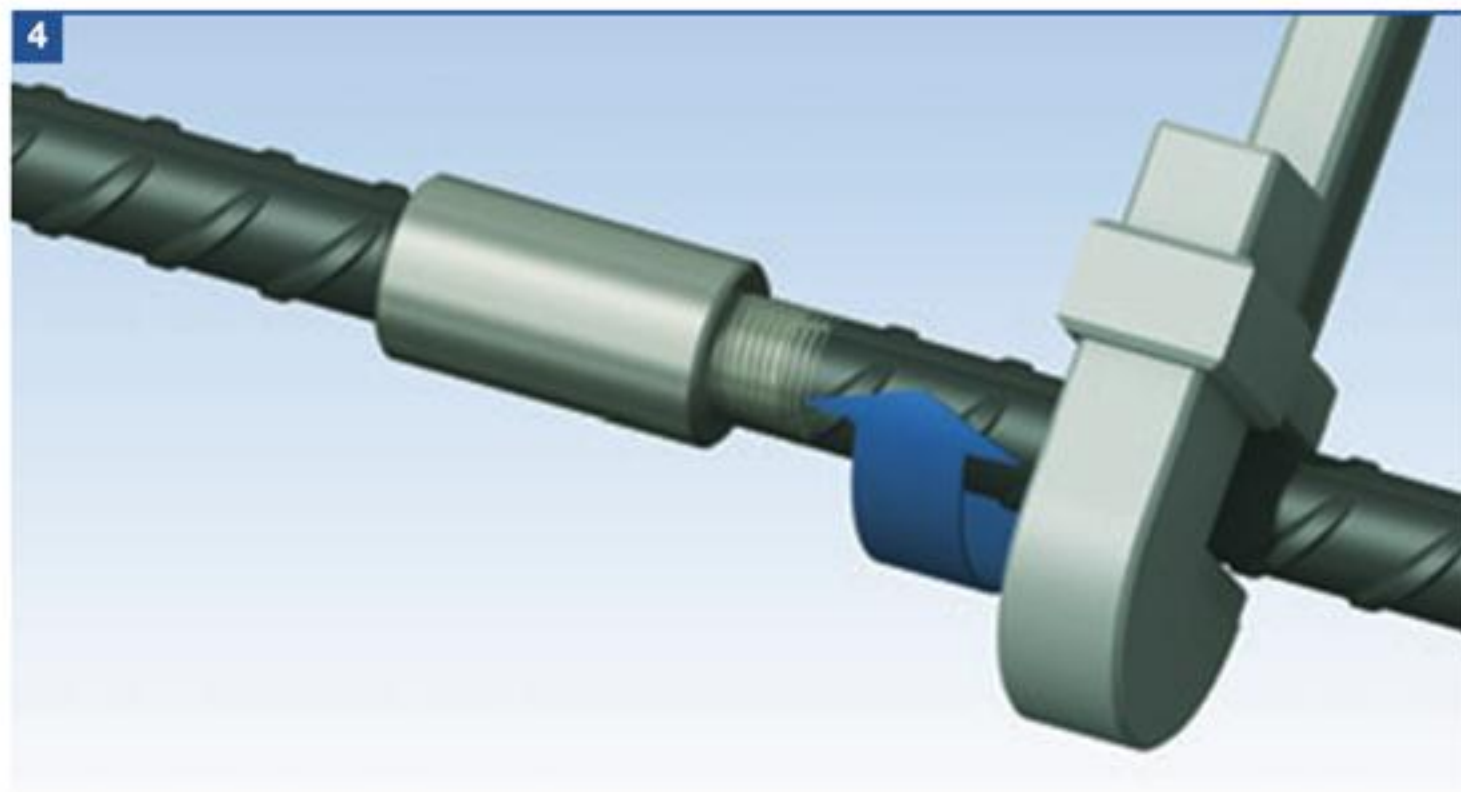

4
Using a wrench, rotate the continuation bar to lock the two bar ends against each other within the coupler. After tightening, the length of exposed thread should be no more than half of the coupler length plus 2-4mm depending on the diameter of the rebar.



The Bartec Type C System

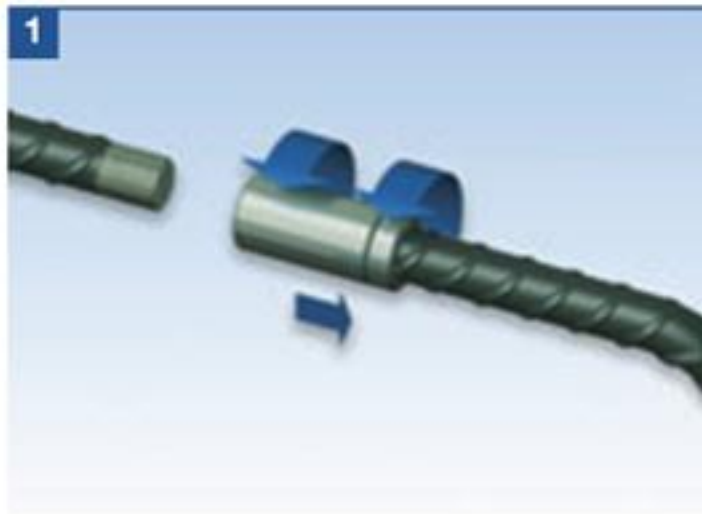

1 Screw the locknut followed by the coupler to the rear of the thread on the continuation bar.



2 Position the continuation bar with the coupler against the end of the first bar.

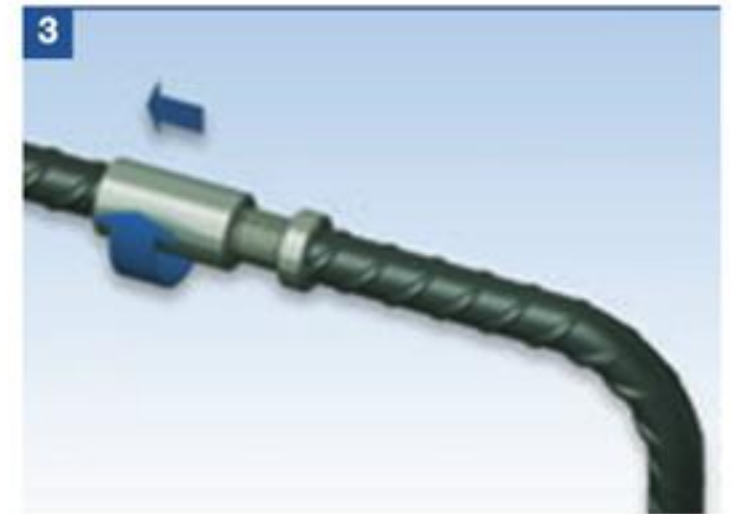

3 Rotate the coupler from the continuation bar to engage against the rear of the thread on the opposing bar and lock tight.

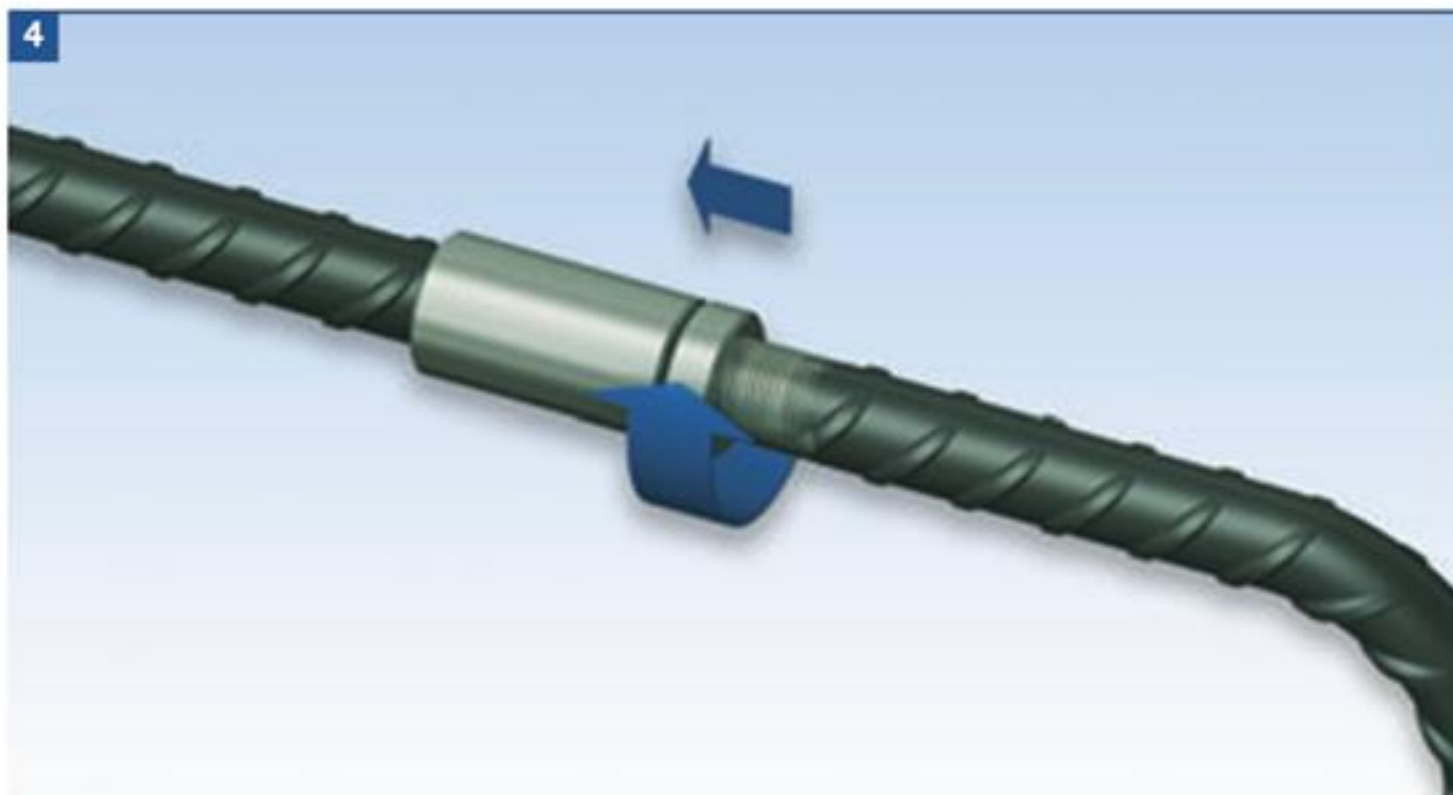

4 Rotate the locknut along the continuation bar to abut the coupler.



5

Hold the rebar in its required orientation and with a wrench tighten the locknut against the coupler.



Reinforcing Bar Couplers

Bar X-L Couplers

Bar X-L couplers provide a cost-effective, full strength joint and are the smallest coupler in the Ancon range. They are particularly appropriate for applications where fatigue is an issue.



Each bar to be joined is cut square and marginally enlarged by a

cold forging process in order to increase the cross sectional area of the bar. This ensures that the joint is stronger than the bar. The Bar X-L system differs from the Bartec system because the thread applied to the bar is rolled onto the enlarged ends of the bar rather than cut into it. As with the Bartec system the threaded end is then proof tested to a force equal to the characteristic yield strength of the bar. This method of thread formation provides Bar X-L couplers with enhanced fatigue resistance.

Where fatigue is a major consideration on a project, the external surface of the coupler can be profiled. Plastic end sheaths protect the threaded ends of the rebar. The internal threads of the couplers, which are usually supplied fixed to the bar, are protected by internal plastic end caps. For certain applications, for example where Bar X-L is being used in deep pours, the coupler end caps may not prevent the ingress

of concrete fines. In such circumstances, it may be necessary to provide additional protection.

Bar X-L couplers are also available to join bars of different diameters. For further information please contact Ancon Building Products.

The Bar X-L system is only available in selected territories in mainland Europe. Please contact Ancon for locations.



Bar X-L Dimensions

Bar Diameter		12	14	16	18	20	22	24	25	26	28	32	36	40	50
External Diameter	<i>d</i>	19	22	25	28	31	34	36	40	40	43	49	55	60	75
Coupler Length	<i>l</i>	28	32	36	40	44	48	52	56	58	62	70	78	86	106
Thread Size		M14	M16	M18	M20	M22	M24	M26	M28	M29	M31	M35	M39	M43	M53
Thread Pitch		2.0	2.0	2.5	2.5	2.5	2.5	2.5	3.0	3.0	3.0	3.5	3.5	4.0	4.0
Weight (kg)		0.03	0.05	0.08	0.11	0.14	0.19	0.20	0.29	0.32	0.39	0.58	0.81	1.09	2.08
Part No Type A		XL12/A	XL14/A	XL16/A	XL18/A	XL20/A	XL22/A	XL24/A	XL25/A	XL26/A	XL28/A	XL32/A	XL36/A	XL40/A	XL50/A
Part No Type B		XL12/B	XL14/B	XL16/B	XL18/B	XL20/B	XL22/B	XL24/B	XL25/B	XL26/B	XL28/B	XL32/B	XL36/B	XL40/B	XL50/B
Part No Type C		XL12/C	XL14/C	XL16/C	XL18/C	XL20/C	XL22/C	XL24/C	XL25/C	XL26/C	XL28/C	XL32/C	XL36/C	XL40/C	XL50/C

Bar X-L Type A

The Bar X-L Type A system utilises internally threaded couplers with a single right hand thread and is suitable for applications where the continuation bar can be rotated. The ends of the bar are upset and threaded for half the length of the coupler.

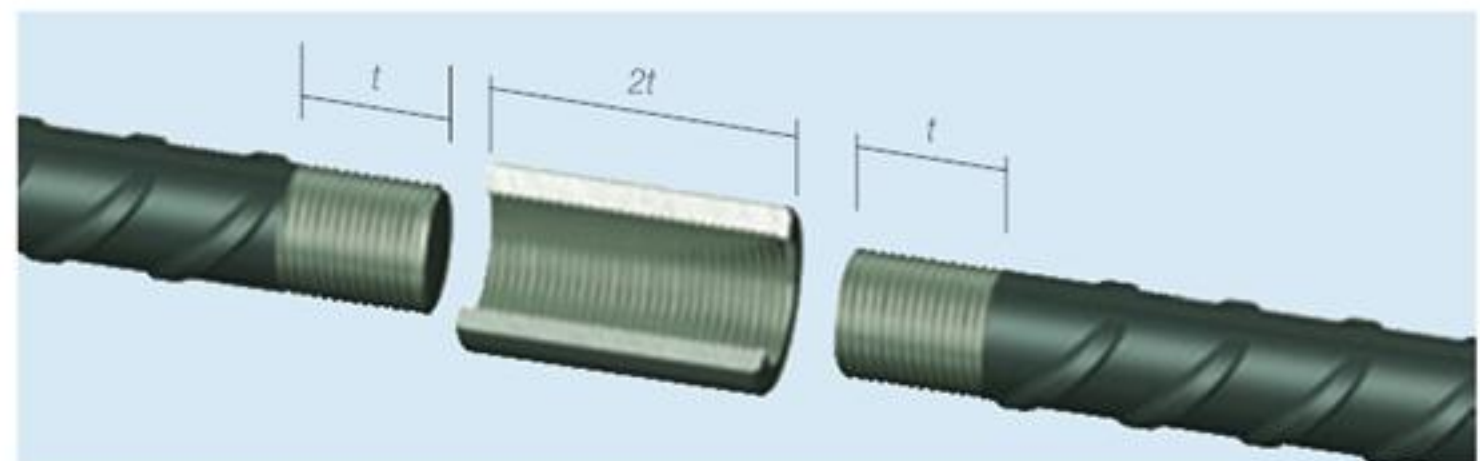

Bar X-L Type B

The Bar X-L Type B uses the same coupler as the Type A system, but one bar is threaded for a full coupler length. This is for applications where it is difficult but not impossible to rotate the continuation bar.

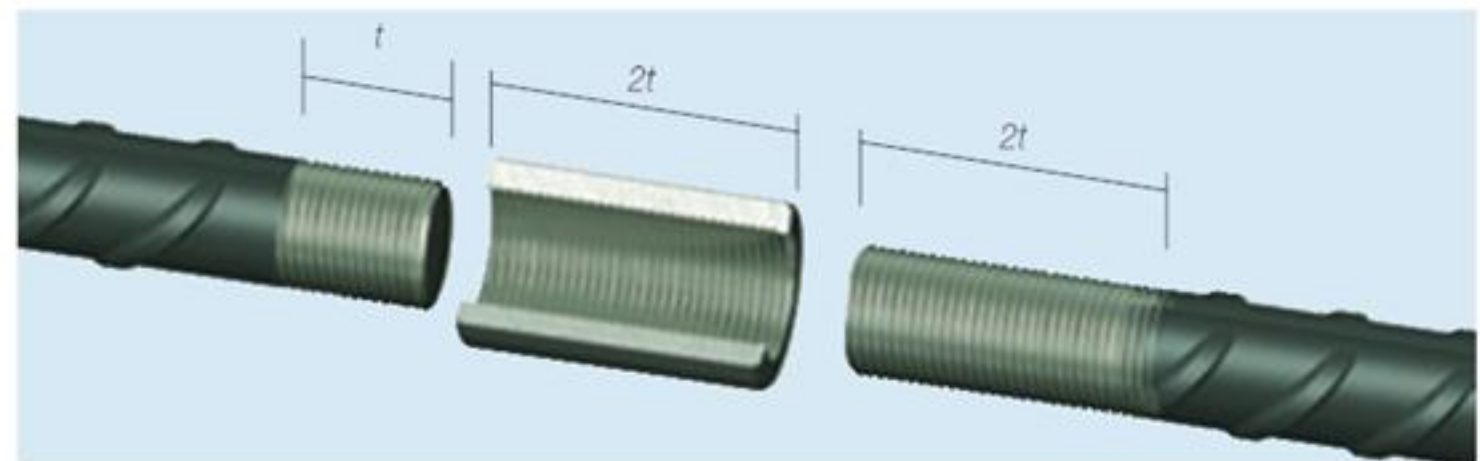

Bar X-L Type C

Where fatigue is a major consideration, the Bar X-L Type C system has additional locknuts and is used where the connecting bar cannot be rotated. The continuation bar is threaded for the full coupler length plus the length of the locknut.

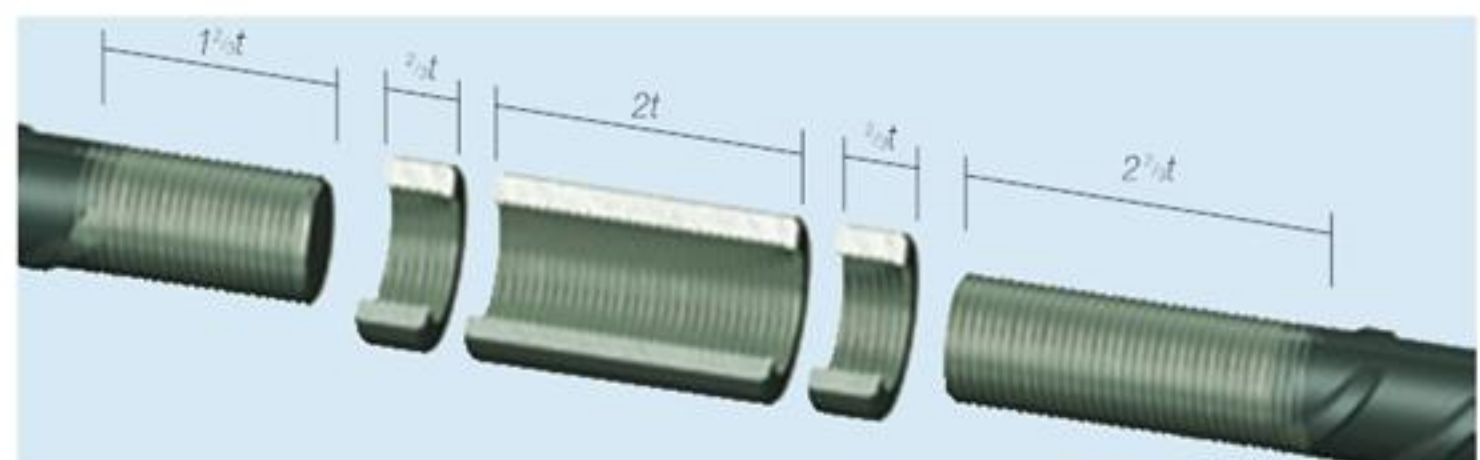

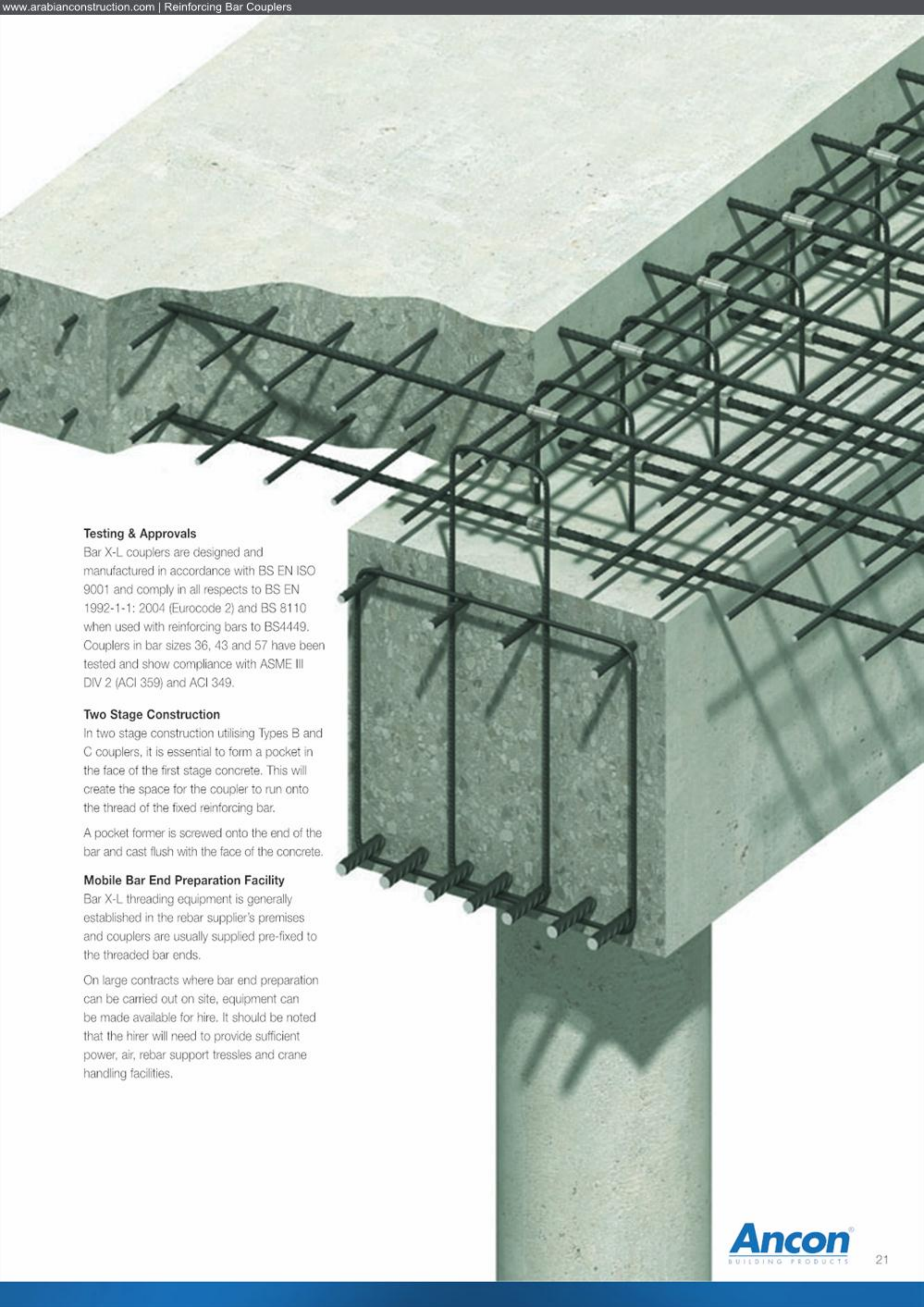

Testing & Approvals

Bar X-L couplers are designed and manufactured in accordance with BS EN ISO 9001 and comply in all respects to BS EN 1992-1-1: 2004 (Eurocode 2) and BS 8110 when used with reinforcing bars to BS4449. Couplers in bar sizes 36, 43 and 57 have been tested and show compliance with ASME III DIV 2 (ACI 359) and ACI 349.

Two Stage Construction

In two stage construction utilising Types B and C couplers, it is essential to form a pocket in the face of the first stage concrete. This will create the space for the coupler to run onto the thread of the fixed reinforcing bar.

A pocket former is screwed onto the end of the bar and cast flush with the face of the concrete.

Mobile Bar End Preparation Facility

Bar X-L threading equipment is generally established in the rebar supplier's premises and couplers are usually supplied pre-fixed to the threaded bar ends.

On large contracts where bar end preparation can be carried out on site, equipment can be made available for hire. It should be noted that the hirer will need to provide sufficient power, air, rebar support tressles and crane handling facilities.

Reinforcing Bar Couplers

Installation

The Bar X-L Type A System

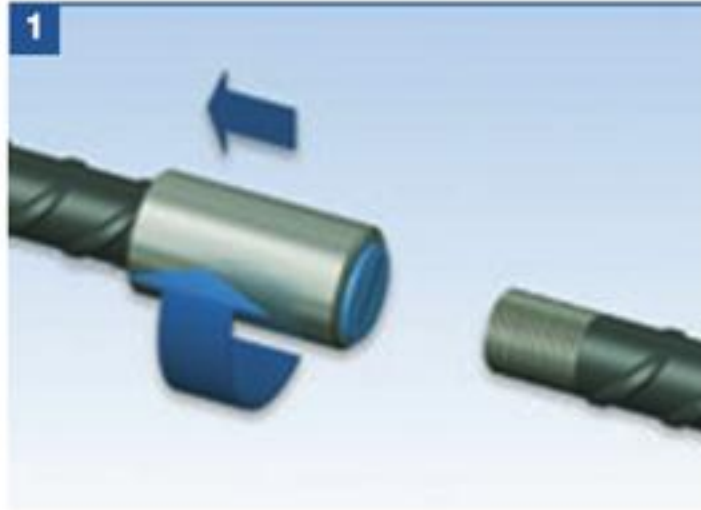

1 Run the coupler to the end of the thread on the fixed bar.

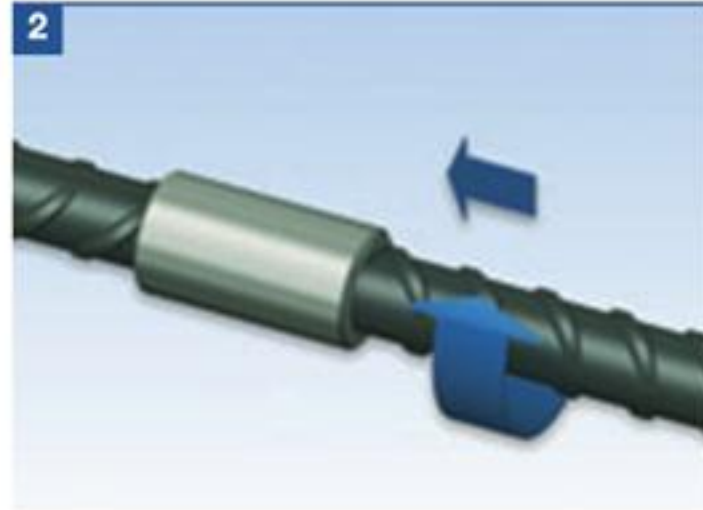

2 Remove the plastic cap from the coupler. Position and rotate the continuation bar in the coupler.

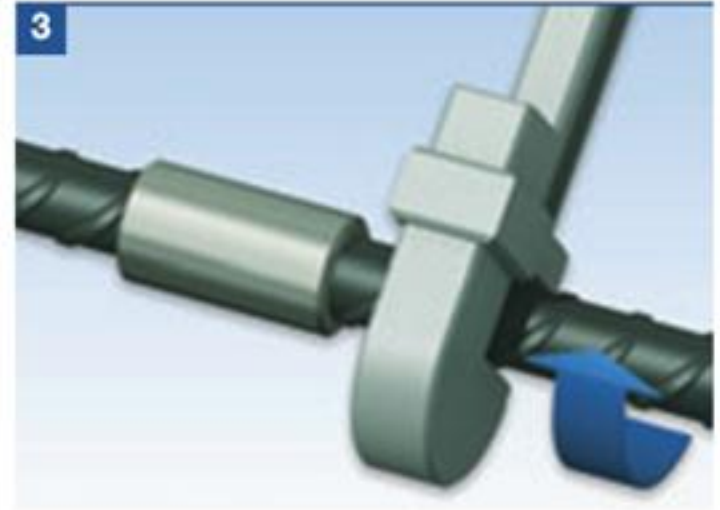

3 Tighten the joint using a wrench on the continuation bar.



The Bar X-L Type B System

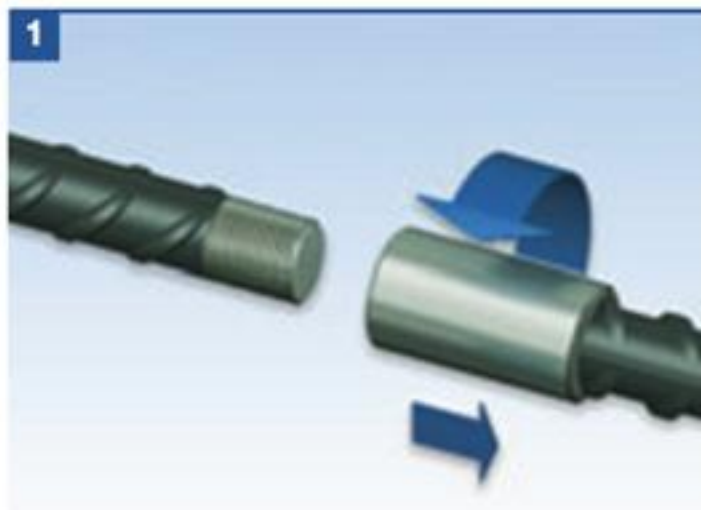

1 Run the coupler to the end of the thread on the continuation bar.

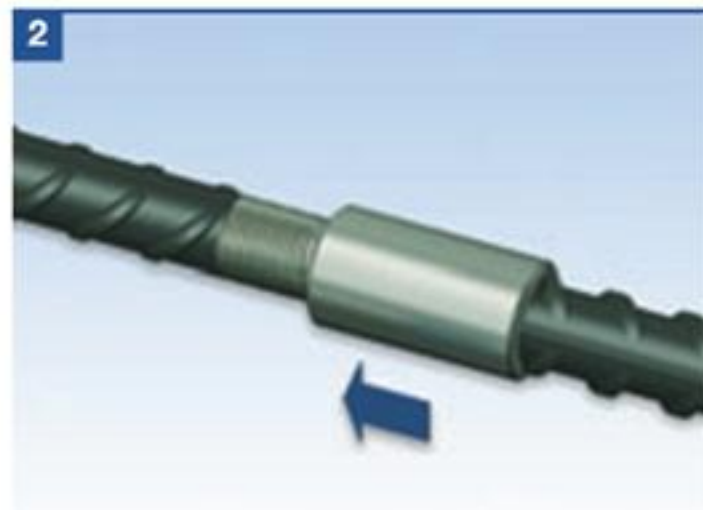

2 Position the continuation bar with the coupler against the end of the fixed bar.

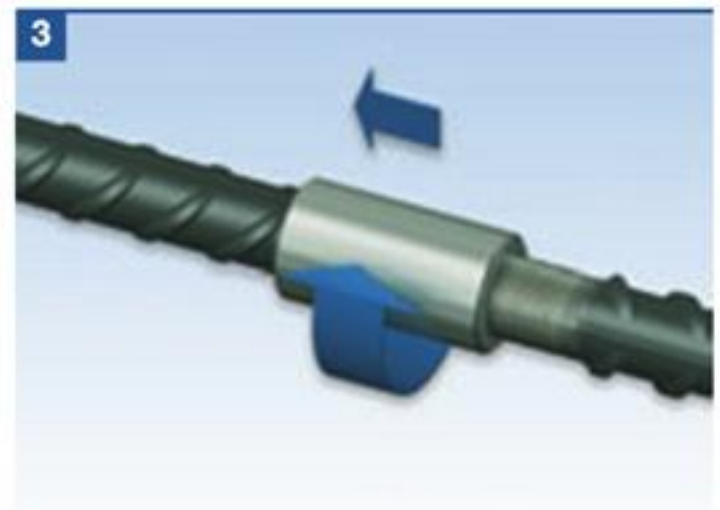

3 Run the coupler from the continuation bar onto the fixed bar.

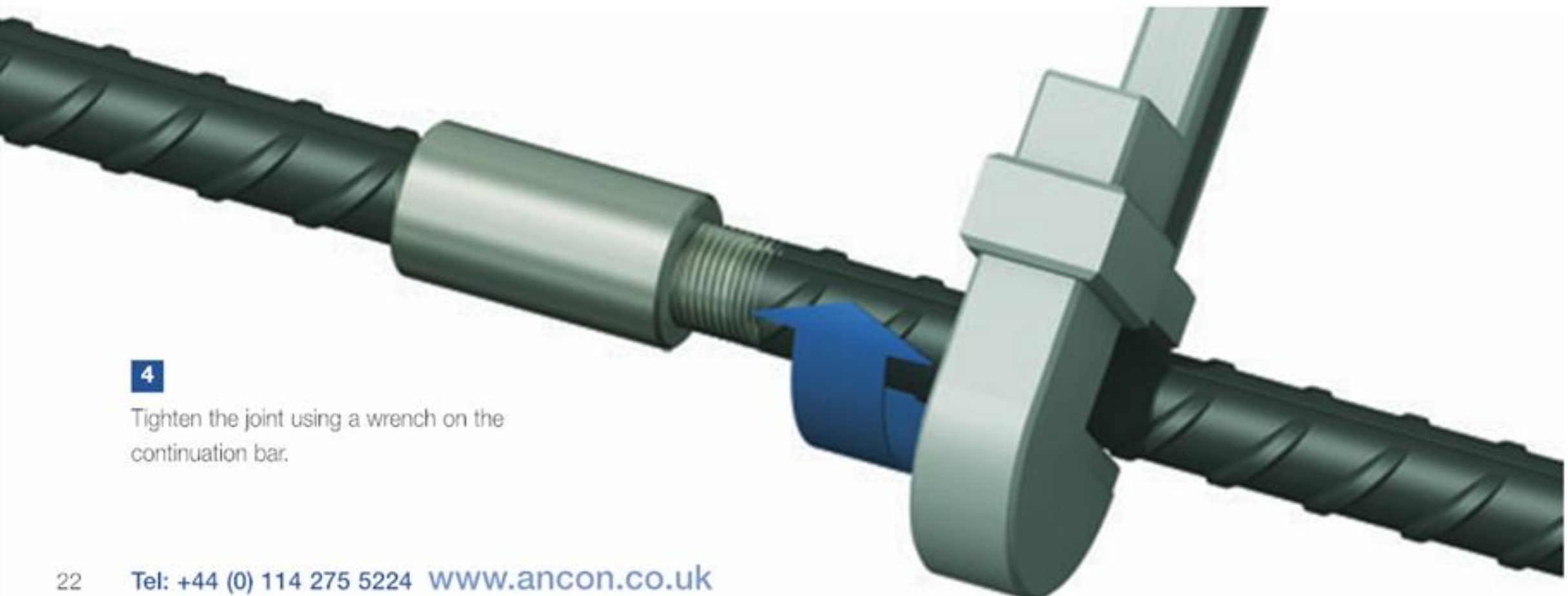

4 Tighten the joint using a wrench on the continuation bar.

The Bar X-L Type C System

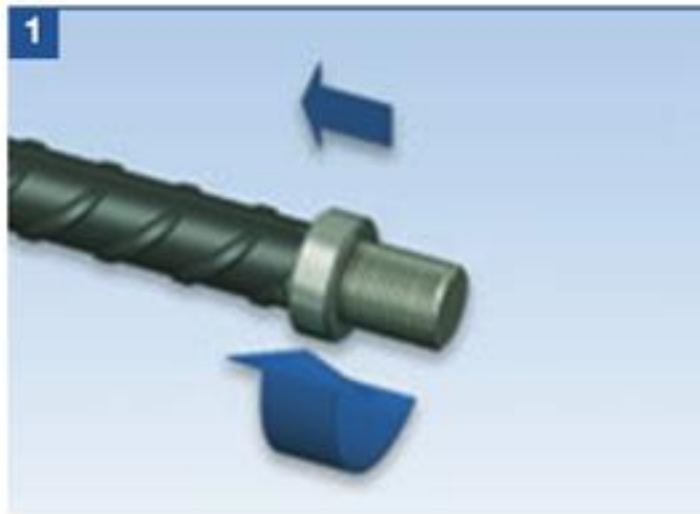

1 Run the locknut onto the fixed bar.

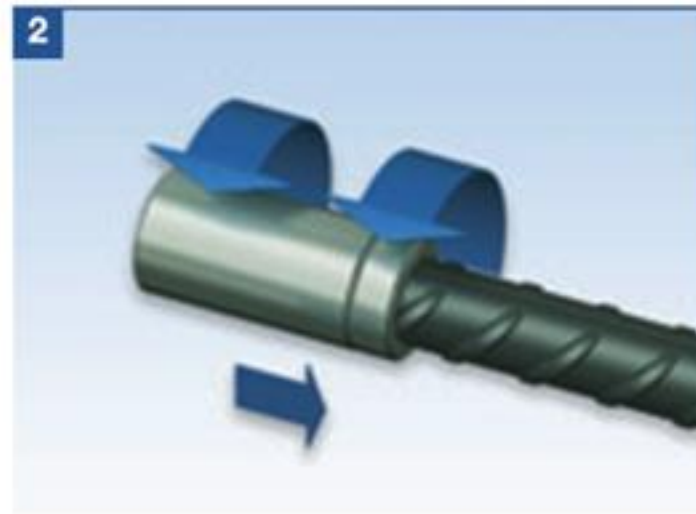

2 Run the second locknut followed by the coupler to the end of the thread on the continuation bar.



3 Position the continuation bar with the coupler against the end of the fixed bar.

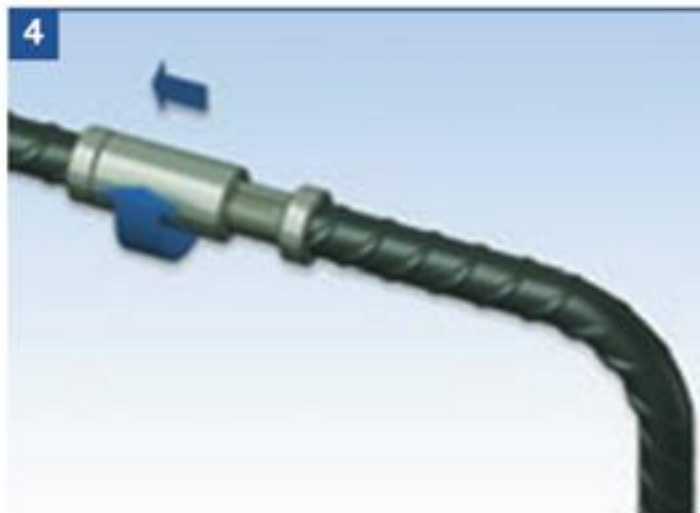

4 Run the coupler from the continuation bar onto the fixed bar.

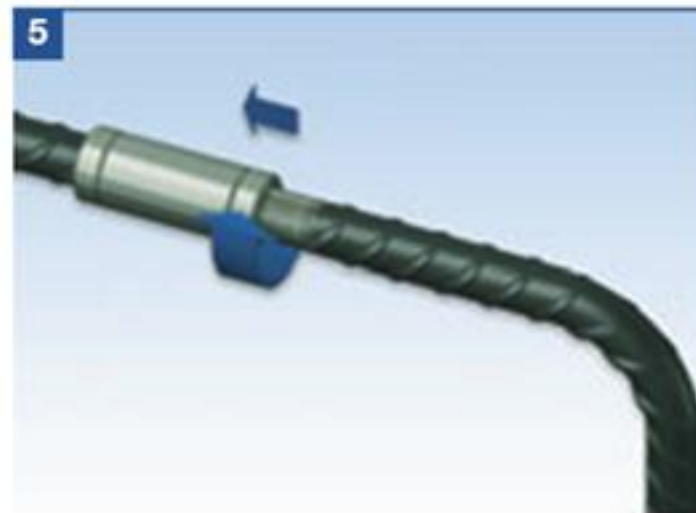

5 Run the locknut along the continuation bar to abut the coupler.

6 Tighten the locknuts against each other using a pair of wrenches.

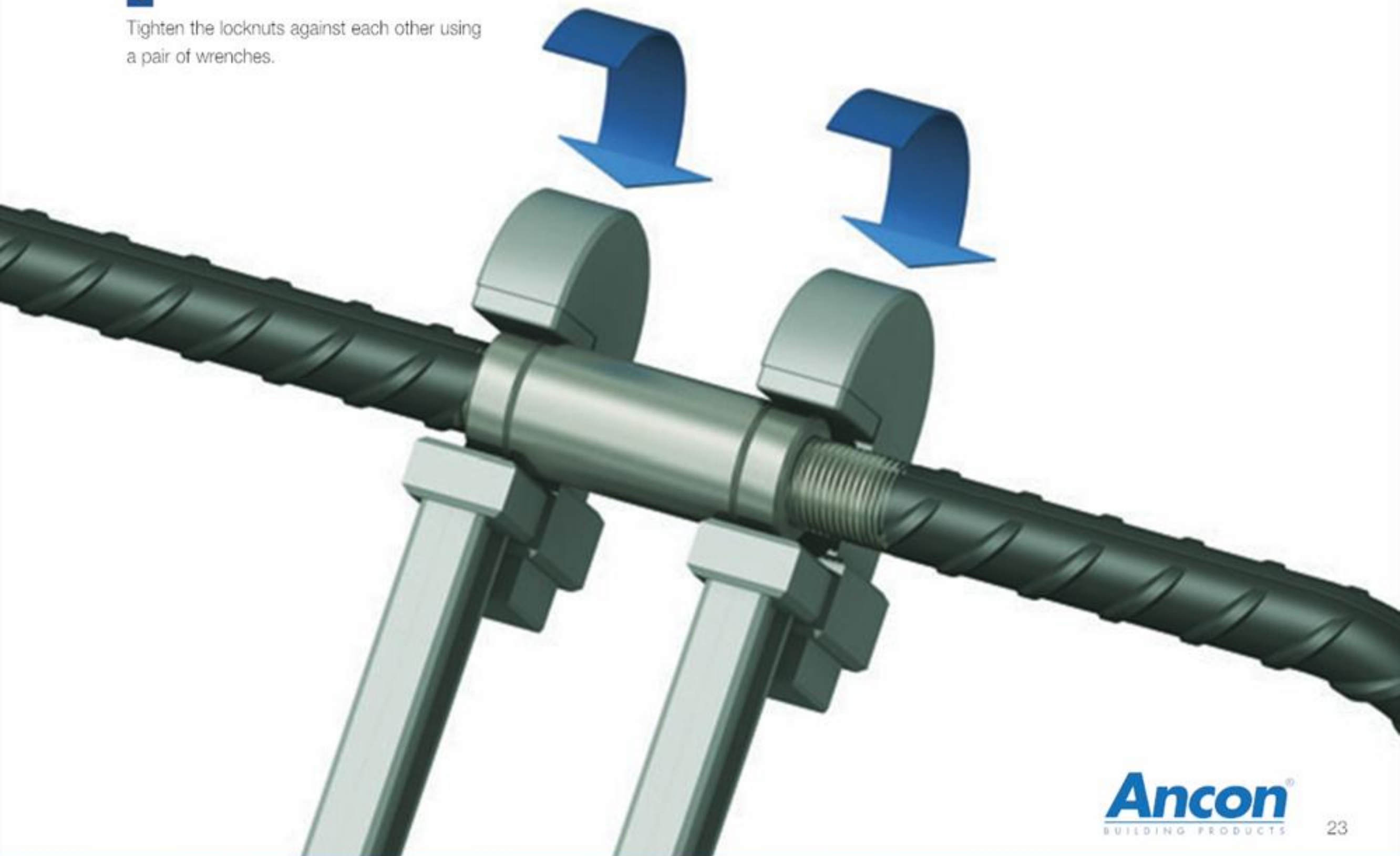

Reinforcing Bar Couplers

MBT

The MBT range of couplers provides a cost-effective method of joining reinforcing bars, particularly when the fixed bar is already in place and there is insufficient space for a hydraulic swaging press.

MBT Couplers are easy to install and achieve failure loads higher than 115% of the characteristic yield strength of grade 500 reinforcing bar. Neither bar end preparation to form threads, nor bar rotation are required. MBT couplers can also be used to join imperial, plain round or deformed reinforcing bars.

The bar ends are supported within the coupler by two serrated saddles, and as the lockshear bolts are tightened, the conical ends embed themselves into the bar. As this happens the serrated saddles bite into both the bar and the shell of the coupler. The lockshear bolts of couplers up to and including the ET20 can be tightened using a ratchet wrench. For larger couplers a nut runner is recommended.

In all cases heavy duty sockets should be used. When the pre-determined tightening torque for the bolts is reached, the heads shear off leaving the top of the installed bolt slightly proud of the coupler. This provides an instant visual check of correct installation.

Note: Impact tools must not be used to tighten lockshear bolts.

MBT ET Series

The MBT ET series of couplers is used to connect reinforcing bars of the same size.

Testing & Approvals

Full destructive tests are carried out on selected couplers from our stocks. MBT couplers are designed and manufactured in accordance with BS EN ISO 9001. The most common sizes of ET series couplers are approved by the BBA and are covered by the Roads and Bridges Agrément Certificate No. 98/R102. Sizes ET10, 12, 14, 16, 20, 25 and 28 have been tested and approved by the DIBt and are covered by Approval No Z-1.5-10. In addition the coupler has been tested to show compliance with the following international design codes:- BS EN 1992-1-1: 2004 (Eurocode 2), BS5400, BS8110, ACI 318 and DIN 1045 German code.



DIBt

Note: Not all coupler types and sizes are relevant to the national approvals shown. For details of coupler types and sizes relevant to each national approval please refer to the relevant approval document, which is available on request.

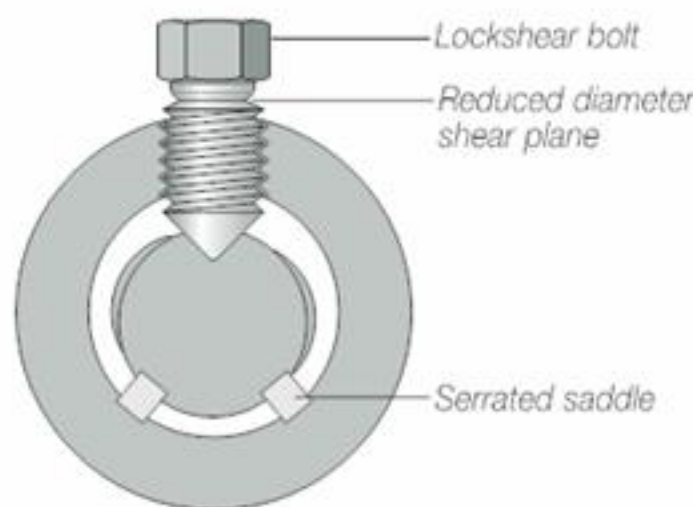

Section showing the embedment of the lockshear bolts and saddles into the bar and the shell of the coupler

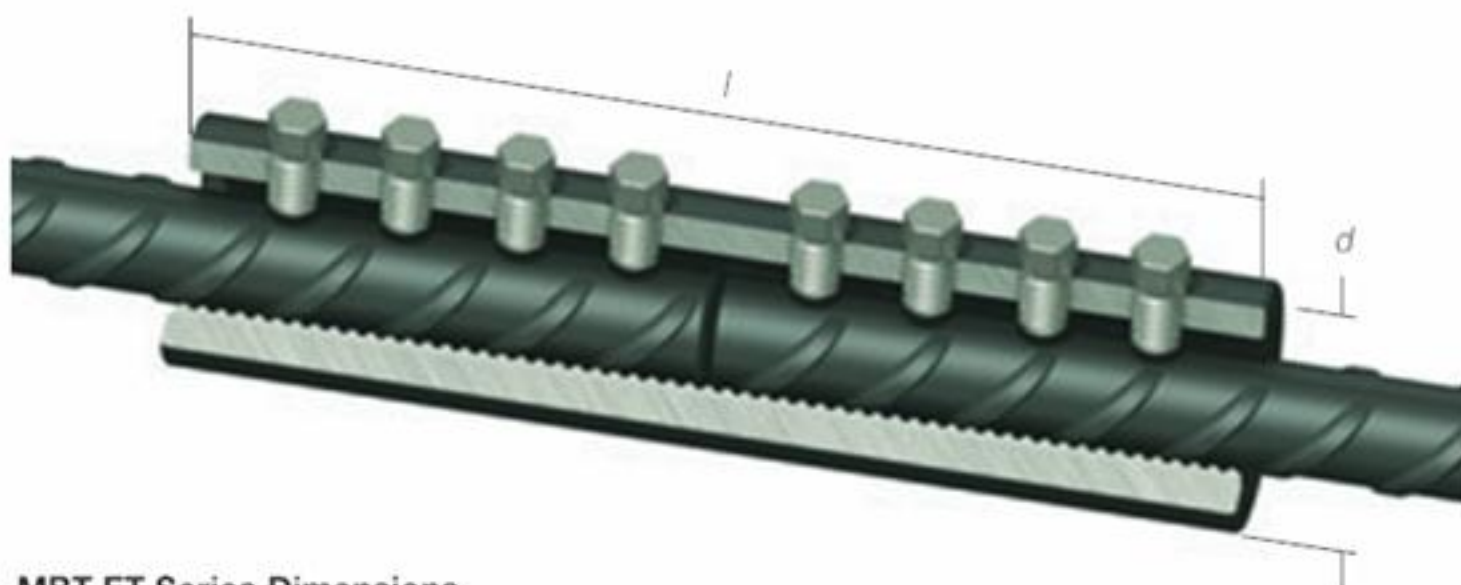

MBT ET Series Dimensions

Bar Diameter		10	12	14	16	18	20	22	25	26	28	30	32	34	36	40
External Diameter	<i>d</i>	33.4	33.4	42.2	42.2	48.3	48.3	48.3	54.0	66.7	66.7	71.0	71.0	75.0	85.0	81.0
Total Length	<i>l</i>	100	140	160	160	204	204	248	258	312	312	312	312	420	484	484
Socket Size A/F (ins)		1/2	1/2	1/2	1/2	1/2	1/2	1/2	3/8	3/8	3/8	3/8	3/8	3/4	3/4	3/4
No. of Bolts		4	6	6	6	8	8	8	8	10	10	10	10	12	14	14
Approx Weight (kg)		0.52	0.72	1.25	1.25	2.0	1.96	2.38	3.00	5.91	5.80	6.68	6.50	8.85	15.30	11.30
Part No.		ET10	ET12	ET14	ET16	ET18	ET20	ET22	ET25	ET26	ET28	ET30	ET32	ET34	ET36	ET40

Note: MBT ET50 couplers can be manufactured. For details contact Ancon Building Products.

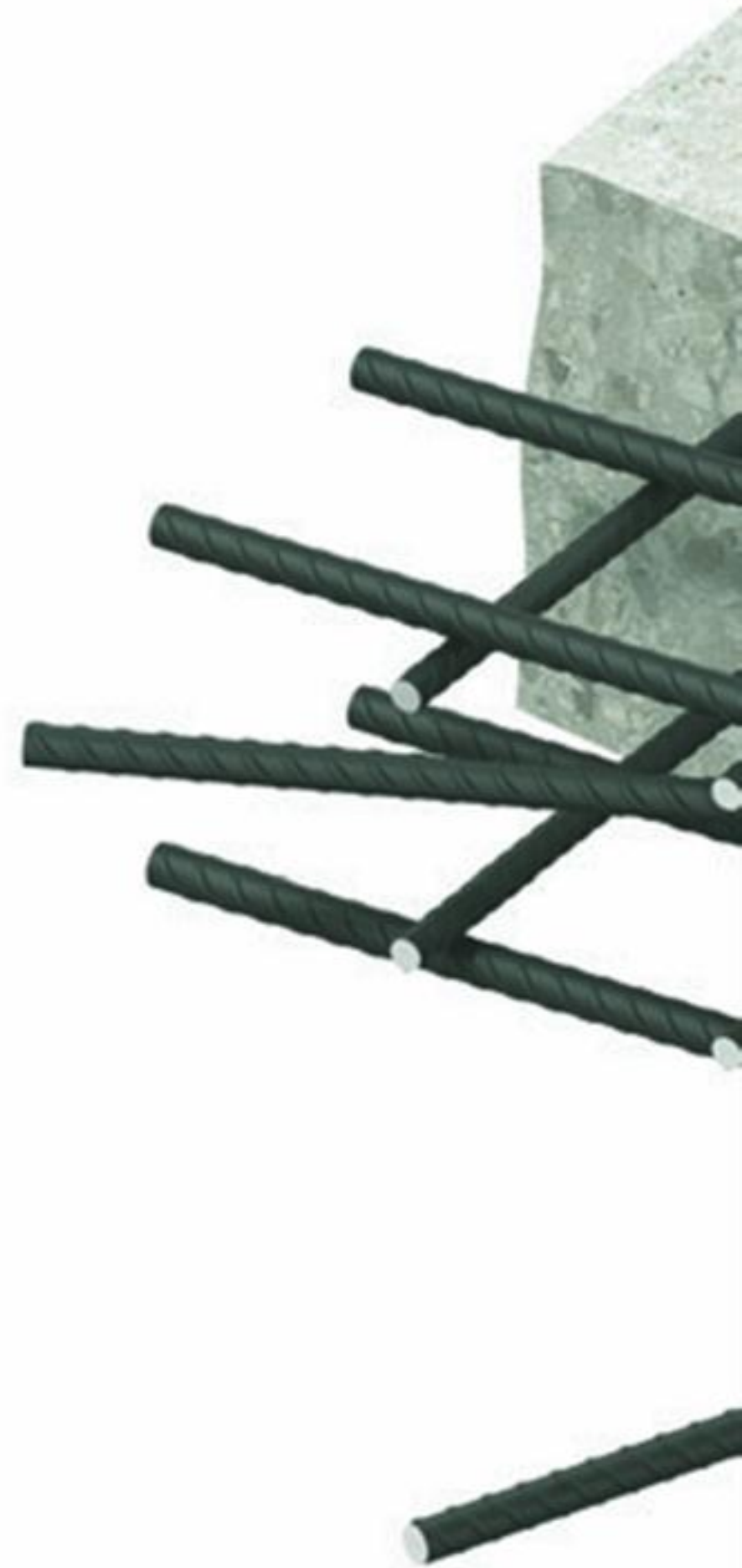

Installation MBT ET Series

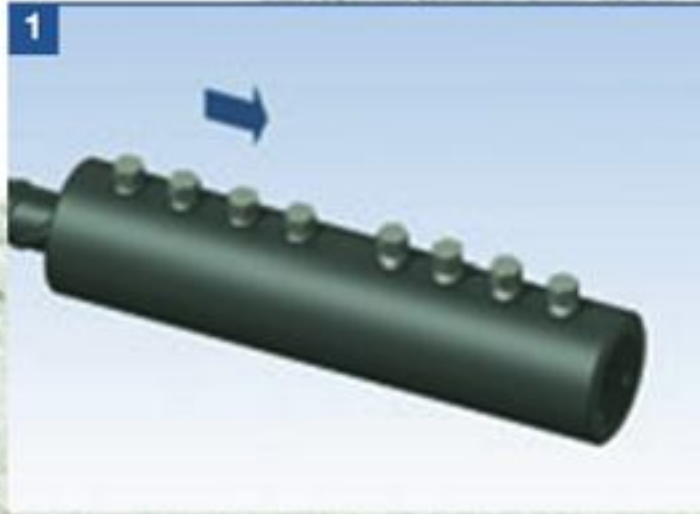

1 Place the coupler over the end of the bar to half the coupler length +/- 6mm and finger tighten the lockshear bolts onto the bar. Check the alignment and make any necessary adjustments.

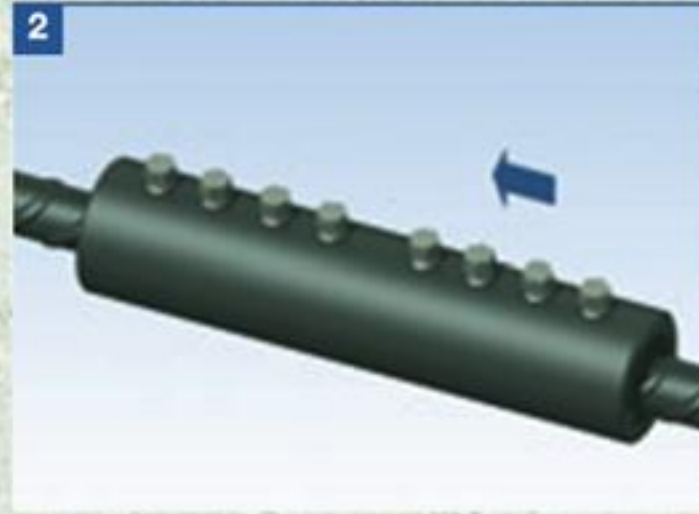

2 Place the other bar end into the coupler until it pushes up against the first bar and finger tighten the remaining lockshear bolts. Check alignment and make any adjustments.

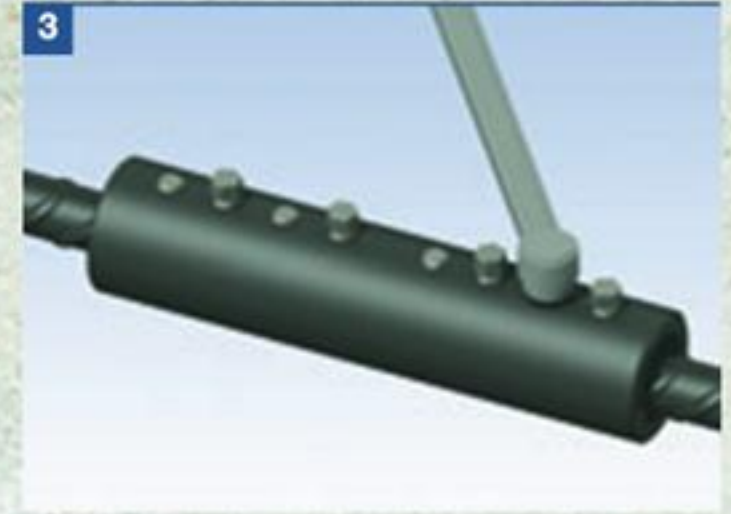

3 Fully tighten the lockshear bolts using either a ratchet wrench or a nut runner as appropriate. Do not use impact tools. Tighten all bolts in a random alternating pattern until all the heads of all the bolts shear off.



Reinforcing Bar Couplers



MBT Transition Series

The MBT Transition series of couplers provides an effective solution for connecting bars of different diameters.

Transition couplers have all of the benefits of the ET series and are designed to achieve failure loads higher than 115% of the characteristic yield strength of the smaller grade 500 reinforcing bar.

They can be installed without any preparation to the bar ends and without any need to rotate bars.

The coupler can be rotated to allow access to the bolts for tightening with either a ratchet wrench or a nut runner. In all cases heavy duty sockets should be used. Transition couplers are non-standard and are made to order.

Note: Impact tools should not be used to tighten lockshear bolts.

Repair and Remedial Work

For applications involving replacement of corroded or damaged bars, the replacement bar is cut approximately 5mm shorter to allow clearance for insertion between the sound ends of the original bars. MBT couplers are pushed fully over both ends of the replacement bar and temporarily held in position.

The replacement bar is then correctly positioned and the couplers moved to a previously marked position on the existing bars indicating half the length of the coupler. The lockshear bolts are tightened to complete the installation.

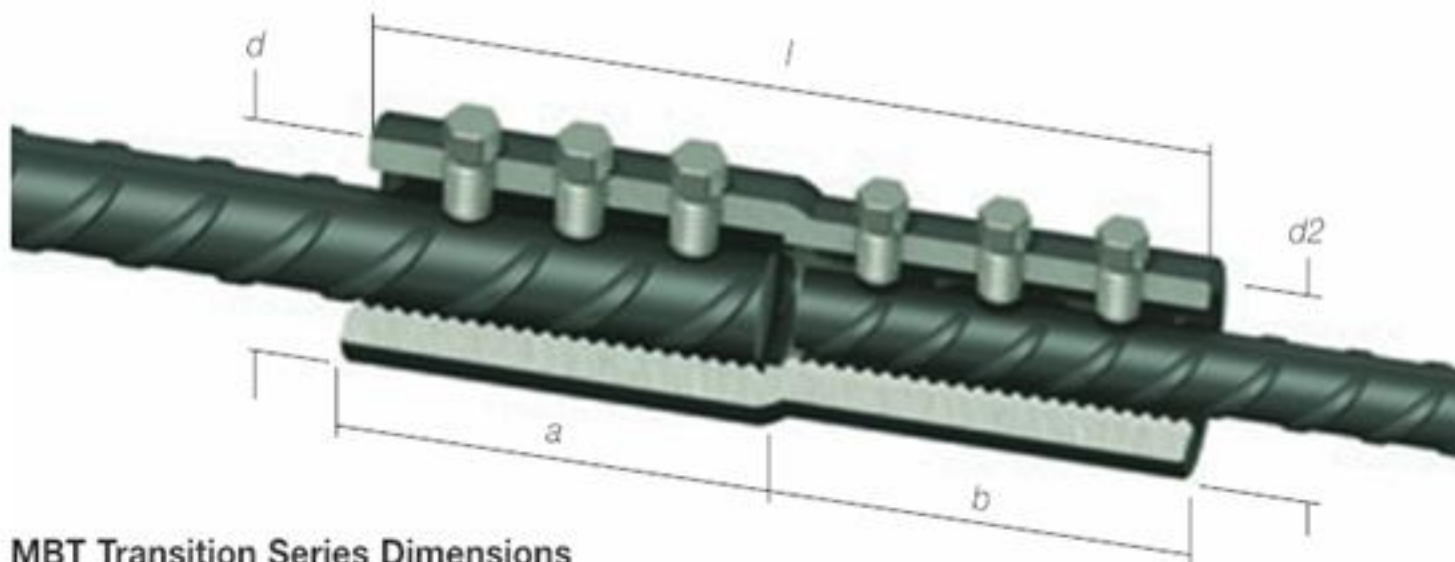

MBT Transition Series Dimensions

Bar Diameter		16/12	16/14	20/12	20/16	25/16	25/20	28/20	28/22	28/25	32/20	32/25	32/28	40/32
External Diameter	<i>d</i>	42.2	42.2	48.3	48.3	54.0	54.0	66.7	66.7	66.7	71.0	71.0	71.0	81.0
External Diameter	<i>d2</i>	26.4	42.2	33.4	48.3	42.2	54.0	48.3	41.7	54.0	48.3	54.0	66.7	71.0
Total Length	<i>l</i>	160	160	150	160	155	180	204	253	258	177	231	286	335
Individual Lengths	<i>a:b</i>	80:80	80:80	80:70	80:80	75:80	90:90	102:102	129:124	129:129	75:102	102:129	130:156	178:157
Socket Size A/F (ns)	<i>a:b</i>	1/2"/1/2"	1/2"/1/2"	1/2"/1/2"	1/2"/1/2"	1/2"/1/2"	1/2"/1/2"	1/2"/1/2"	1/2"/1/2"	1/2"/1/2"	1/2"/1/2"	1/2"/1/2"	1/2"/1/2"	1/2"/1/2"
No. of Bolts	<i>a:b</i>	3:3	3:3	3:3	3:3	2:3	3:3	3:4	4:5	4:4	2:4	3:4	4:5	5:5
Approx Weight (kg)		1.30	1.25	1.13	1.56	1.51	2.23	2.94	3.61	3.98	2.55	3.70	5.71	7.47
Part No.		ET16/12	ET16/14	ET20/12	ET20/16	ET25/16	ET25/20	ET28/20	ET28/22	ET28/25	ET32/20	ET32/25	ET32/28	ET40/32

Installation

MBT Transition Series

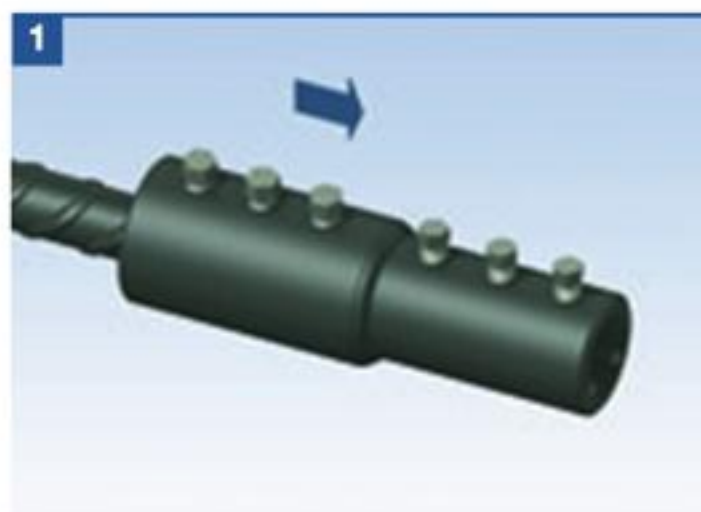

Place the coupler over the end of the bar to the appropriate depth +/- 6mm and finger tighten the lockshear bolts onto the bar. Check the alignment and make any necessary adjustments.

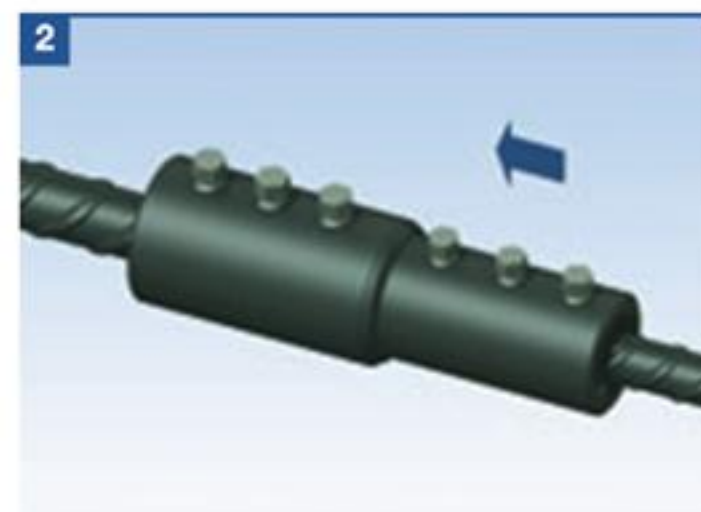

Place the other bar end into the coupler until it pushes up against the first bar and finger tighten the remaining lockshear bolts. Check alignment and make any adjustments.

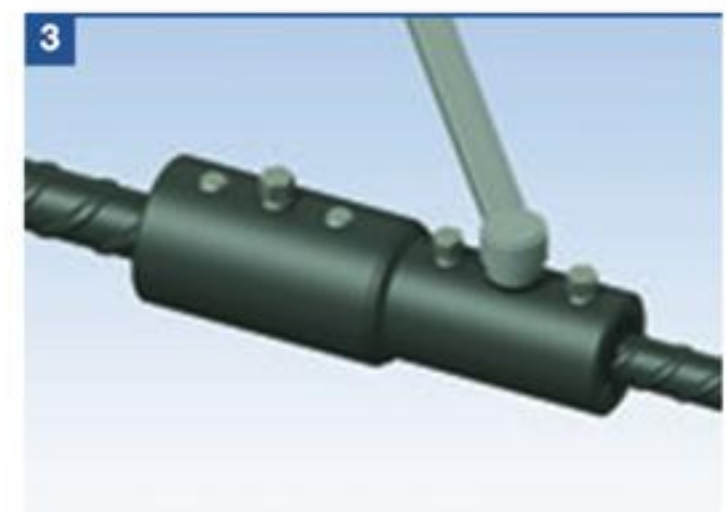

Fully tighten the lockshear bolts using either a ratchet wrench or a nut runner as appropriate. Do not use impact tools. Tighten all bolts in a random alternating pattern until all the heads of all the bolts shear off.



MBT Continuity Series

The MBT Continuity coupler allows reinforcement to be extended at construction joints without the need to drill or otherwise substantially deface the formwork.

The female part of the coupler is fixed to the formwork with the aid of a nail plate.

After removal of the formwork, the nail plate protects the internally threaded end of the coupler. It is advisable to loosen the nail plate to break the bond with the concrete whilst it is still 'green'. When the nail plate is removed, the male section can be screwed into the existing section of the coupler.

The 12mm and 16mm couplers have additional locknuts which are used to secure the connection. The two sections of sizes 20mm to 40mm couplers are locked together by an expanding cone in the male section.



MBT Continuity Series 12mm and 16mm Dimensions

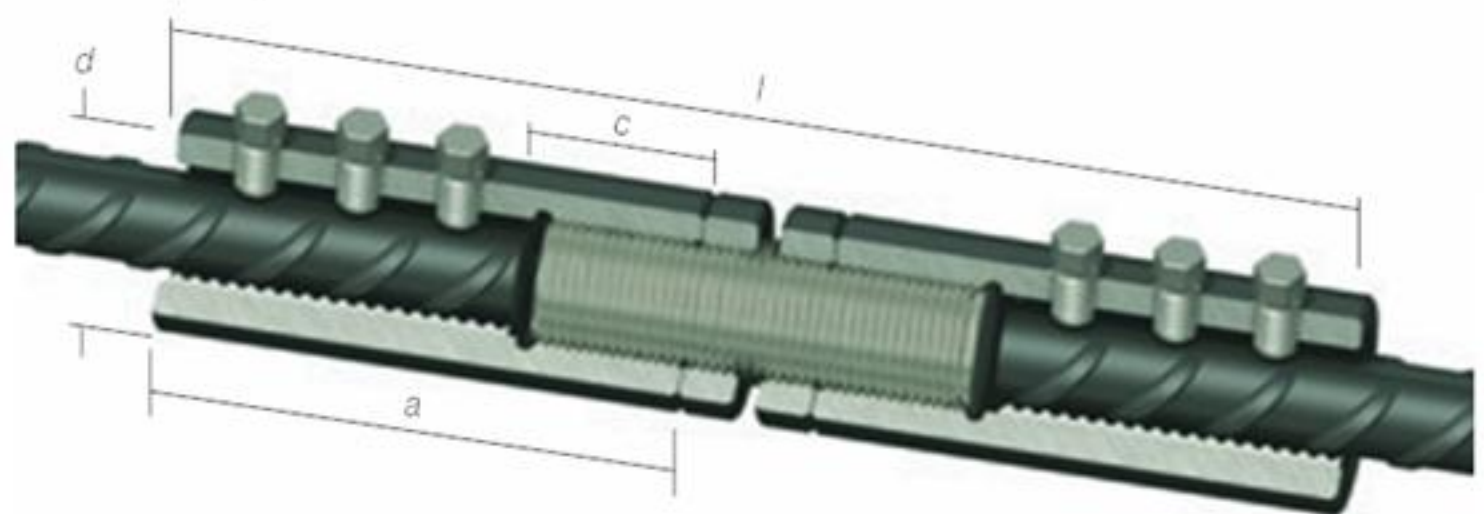

MBT Continuity Series 20mm to 40mm Dimensions

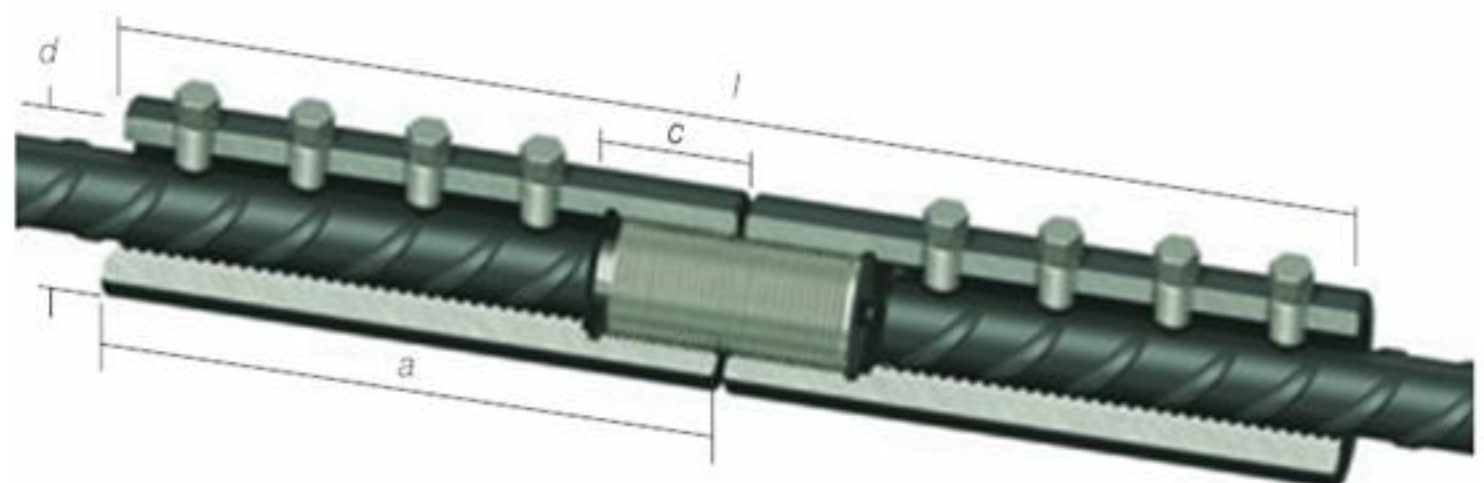

Bar Diameter		12	16	20	25	32	40
External Diameter	<i>d</i>	33.4	42.2	48.3	54.0	71.0	81.0
Maximum Length	<i>l</i>	250	280	297	357	431	603
Female Component Length	<i>a</i>	100	115	147	177	214	300
Threaded Section	<i>c</i>	30	35	38	43	53	53
Socket Size A/F (ins)		1/2	1/2	1/2	3/4	1	1 1/4
No. of Bolts		6	6	8	8	10	14
Nail Plate Diameter x Thickness		75 x 5	75 x 5	75 x 5	100 x 5	100 x 5	127 x 5
Approx Weight (kg)		1.34	2.34	2.85	4.42	9.58	16.17
Part No.		C12	C16	C20	C25	C32	C40

Reinforcing Bar Couplers

Installation

MBT Continuity Series - Sizes 12mm and 16mm



Fix the nail plate to the formwork and fully screw the female component onto the plate. Insert the bar into the coupler, ensuring that it does not encroach into the threaded section. Finger tighten the lockshear bolts. Check alignment and make any adjustments.



Fully tighten the lockshear bolts until the heads shear off. Cast the concrete.

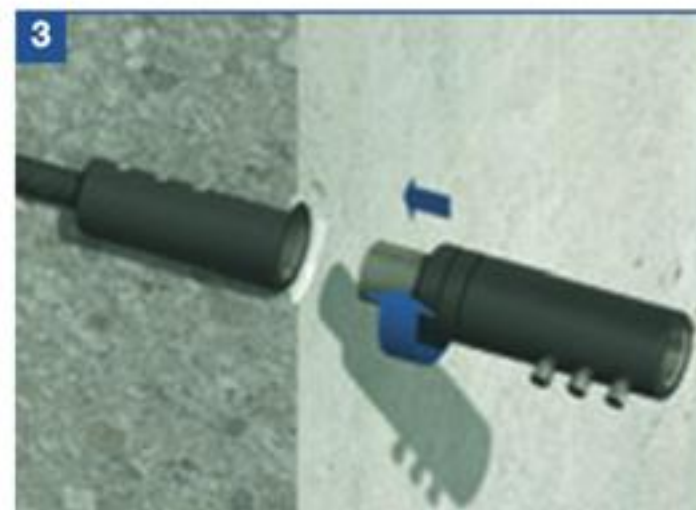

Remove the formwork and unscrew the nail plate. The male component can now be fully screwed into the fixed female component. The male component can be rotated up to a full turn to allow the bolts to be located in an accessible position for tightening.



Run the locknut along the threaded male stud to abut the female component. Fully tighten the locknut against the female section using a wrench.

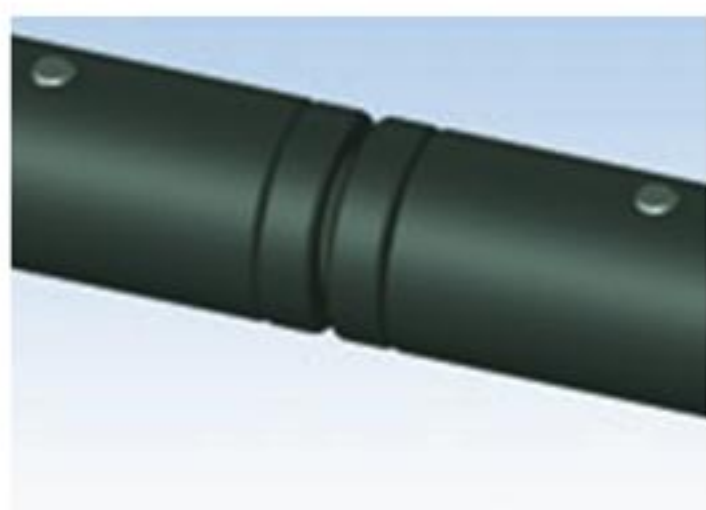

Note: When the coupler is fully assembled the visible threaded stud between the two locknuts must not exceed 20mm.

Note: The Continuity Coupler male component will be delivered with the threaded stud already in place and the locknuts located on the threaded stud. If the female component is to be left in situ for an extended period, the threads must be greased to prevent corrosion.



Place the continuation bar into the male component and finger tighten the bolts. Check alignment and make any adjustments. Fully tighten the lockshear bolts in a random alternating pattern, using a ratchet wrench, until the heads shear off. Do not use impact tools. Fully tighten the locknut.

Installation

MBT Continuity Series - Sizes 20mm to 40mm

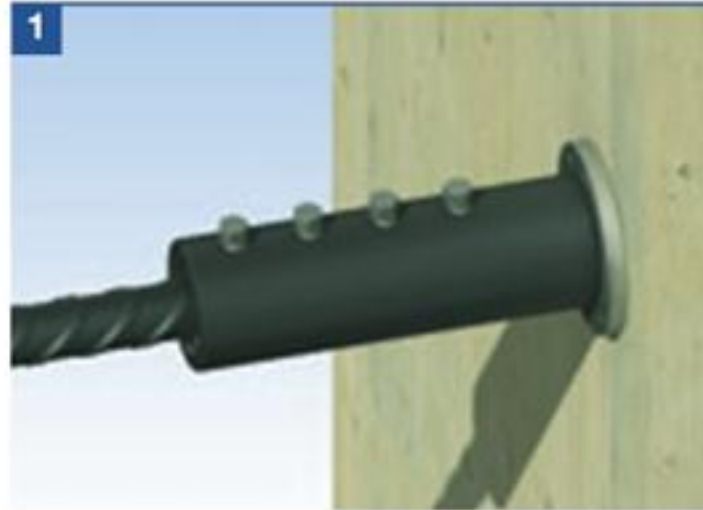

1 Fix the nail plate to the formwork and fully screw the female component onto the plate. Insert the bar into the coupler, ensuring that it does not encroach into the threaded section. Finger tighten the lockshear bolts. Check alignment and make any adjustments.

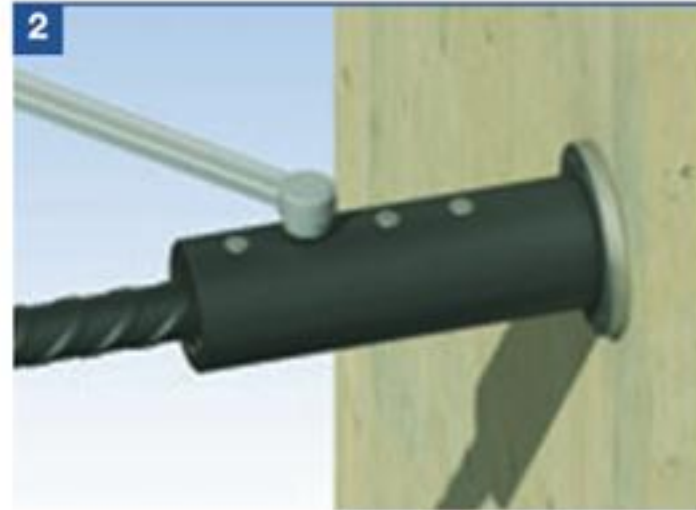

2 Fully tighten the lockshear bolts using a ratchet wrench or an air powered tool, until the heads shear off. Cast the concrete.

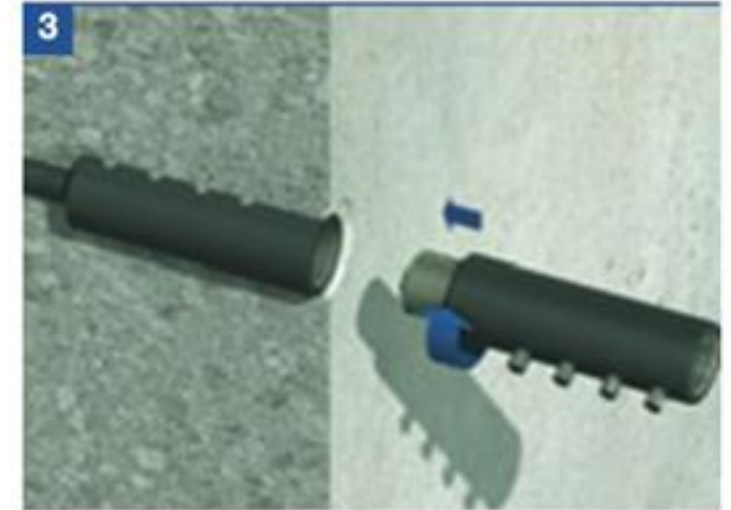

3 Remove the formwork and unscrew the nail plate. The male component can now be fully screwed into the fixed female component. The male component can be rotated up to a full turn to allow the bolts to be located in an accessible position for fixing.



4 The two sections are now locked together by expanding a cone in the centre of the coupler with the tool supplied.



5 Place the continuation bar into the male component and finger tighten the bolts. Check alignment and make any adjustments. Fully tighten the lockshear bolts in a random alternating pattern, using a ratchet wrench or an air powered tool, until the heads shear off. Do not use impact tools.

Note: The Continuity Coupler male component will be delivered with the threaded stud already in place and the locknuts located on the threaded stud. If the female component is to be left insitu for an extended period, the threads must be greased to prevent corrosion.

Reinforcing Bar Couplers

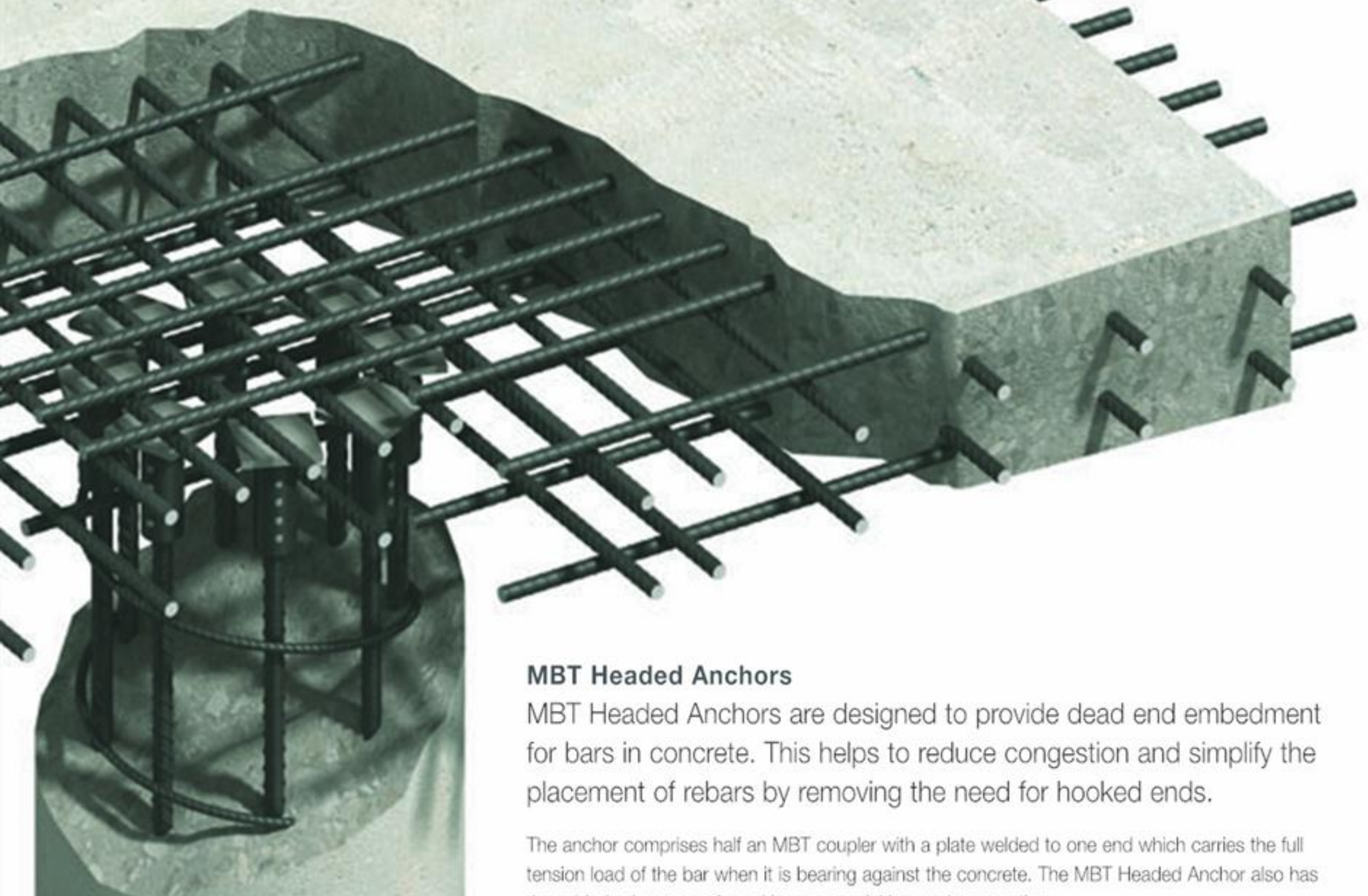

MBT Headed Anchors

MBT Headed Anchors are designed to provide dead end embedment for bars in concrete. This helps to reduce congestion and simplify the placement of rebars by removing the need for hooked ends.

The anchor comprises half an MBT coupler with a plate welded to one end which carries the full tension load of the bar when it is bearing against the concrete. The MBT Headed Anchor also has the added advantage of requiring no special bar end preparation.

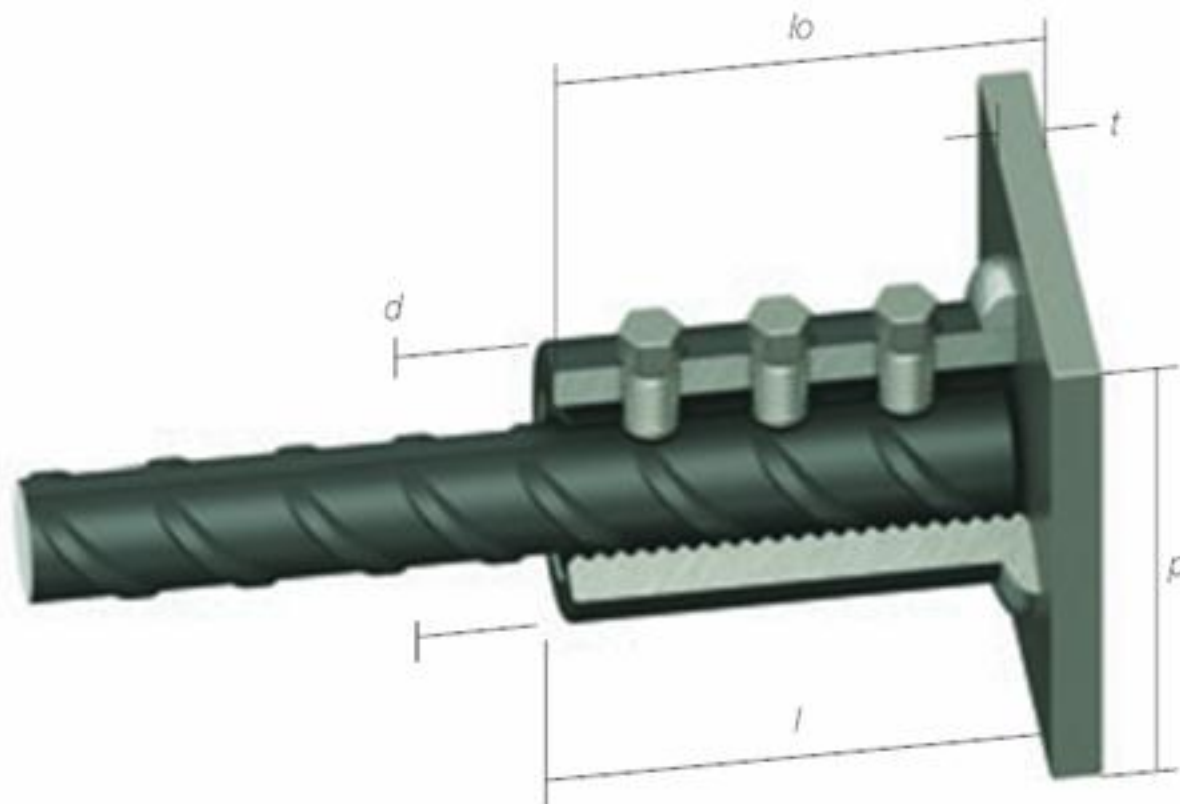

Bar Diameter		10	12	14	16	18	20	22	25	26	28	30	32	34	36	40
External Diameter	d	33.4	33.4	42.2	42.2	48.3	48.3	48.3	54.0	66.7	66.7	71.0	71.0	75.0	85.0	81.0
Coupler Length	l	55	75	82	82	104	104	126	129	156	156	156	156	215	247	247
Total Length	l_0	65	85	92	92	114	114	136	139	168	168	171	171	230	262	262
Plate Thickness	t	10	10	10	10	10	10	10	10	12	12	15	15	15	15	15
Plate w x h	p	70	70	70	80	90	90	90	100	110	110	130	130	130	150	150
Socket Size A/F (ins)		$\frac{1}{2}$	$\frac{1}{2}$	$\frac{1}{2}$	$\frac{1}{2}$	$\frac{1}{2}$	$\frac{1}{2}$	$\frac{1}{2}$	$\frac{3}{8}$	$\frac{3}{8}$	$\frac{3}{8}$	$\frac{3}{8}$	$\frac{3}{8}$	$\frac{3}{8}$	$\frac{3}{8}$	$\frac{3}{8}$
No. of Bolts		2	3	3	3	4	4	5	4	5	5	5	5	6	7	7
Approx Weight (kg)		0.64	0.74	1.01	1.07	1.58	1.58	1.72	2.29	3.81	4.14	5.08	4.72	5.17	9.13	8.30
Part No.		ETHA10	ETHA12	ETHA14	ETHA16	ETHA18	ETHA20	ETHA22	ETHA25	ETHA26	ETHA28	ETHA30	ETHA32	ETHA34	ETHA36	ETHA40

Note: Minimum compressive strength of concrete 25N/mm².



Electric Wrench

To facilitate the installation of MBT couplers Ancon Electric Wrenches are available for purchase or hire. The smooth continuous action of the wrench prevents the early shearing of the lockshear bolts and damage to threads. The wrench is supplied with specially hardened heavy duty sockets. For details please contact Ancon.



Note: Impact tools should not be used to tighten lockshear bolts. In all cases heavy duty sockets should be used.

Other Ancon Products

Reinforcement Continuity Systems

Reinforcement Continuity Systems are an increasingly popular means of maintaining continuity of reinforcement at construction joints in concrete. Ancon Eazistrip is approved by UK CARES and consists of pre-bent bars housed within a galvanised steel casing. Once installed, the protective cover is removed and the bars are straightened. Ancon Starter Bars are supplied fixed to an Ancon coupler. Once cast in concrete, the coupler's end cap is removed and a threaded continuation bar is installed with a calibrated torque wrench to complete the connection.



Shear Load Connectors

Ancon DSD and ESD Shear Load Connectors are used to transfer shear across expansion and contraction joints in concrete. They are more effective at transferring load and allowing movement to take place than standard dowels. The range features rectangular box section sleeves to allow lateral movement in addition to longitudinal movement. A range of Lockable Dowels is available for temporary movement joints in post-tensioned concrete.



Channel and Bolt Fixings

Ancon offers a wide range of channels and bolts in order to fix stainless steel masonry support, restraints and windposts to structural frames. Cast-in channels and expansion bolts are used for fixing to the edges of concrete floors and beams.



Punching Shear Reinforcement

Ancon Shearfix is used within a slab to provide additional reinforcement from punching shear around columns. The system is approved by UK CARES and consists of double-headed steel studs welded to flat rails. Shearfix is designed to suit the load conditions and slab depth at each column using free calculation software from Ancon.



Insulated Balcony Connections

Ancon Isolan connectors join external concrete balconies to internal concrete floor slabs. Used to minimise cold bridging, they provide continuity to the thermal insulation. Standard systems, comprising rigid CFC-free polystyrene insulation and duplex stainless steel shear reinforcement, suit most depths of cantilevered and simply supported balconies. Solutions for steel framed buildings and steel balconies are also available.



Masonry Support Systems

Lintels

Masonry Reinforcement

Windposts and Parapet Posts

Wall Ties and Restraint Fixings

Channel and Bolt Fixings

Tension and Compression Systems

Insulated Balcony Connectors

Shear Load Connectors

Punching Shear Reinforcement

Reinforcing Bar Couplers

Reinforcement Continuity Systems

Stainless Steel Fabrications

Flooring and Formed Sections

Refractory Fixings



Ancon Building Products
President Way, President Park
Sheffield S4 7UR
United Kingdom
Tel: +44 (0) 114 275 5224
Fax: +44 (0) 114 276 8543
Email: info@ancon.co.uk
Visit: www.ancon.co.uk
Follow on Twitter: @AnconUK

Ancon (Middle East) FZE
PO Box 17225
Jebel Ali
Dubai
United Arab Emirates
Tel: +971 (0) 4 883 4346
Fax: +971 (0) 4 883 4347
Email: info@ancon.ae
Visit: www.ancon.ae

Ancon Building Products
114 Kurrajong Avenue
Mount Druitt
Sydney
NSW 2770
Australia
Tel: +61 (0) 2 8808 1111
Fax: +61 (0) 2 9675 3390
Email: info@ancon.com.au
Visit: www.ancon.com.au

Ancon (Schweiz) AG
Gewerbezone Widalmi 10
3216 Ried bei Kerzers
Switzerland
Tel: +41 (0) 31 750 3030
Fax: +41 (0) 31 750 3033
Email: info@ancon.ch
Visit: www.ancon.ch

Ancon Building Products GesmbH
Gerspergasse 9/3 Top 1
A-1210 Vienna
Austria
Tel: +43 (0) 1 259 58 62-0
Fax: +43 (0) 1 259 58 62-40
Email: info@ancon.at
Visit: www.ancon.at

Ancon GmbH
Bartholomäusstrasse 26
90489 Nuremberg
Germany
Tel: +49 (0) 911 955 1234 0
Fax: +49 (0) 911 955 1234 9
Email: info@anconbp.de
Visit: www.anconbp.de

These products are available from:



© Ancon Building Products 2012

The construction applications and details provided in this literature are indicative only. In every case, project working details should be entrusted to appropriately qualified and experienced persons.

Whilst every care has been exercised in the preparation of this document to ensure that any advice, recommendations or information is accurate, no liability or responsibility of any kind is accepted in respect of Ancon Building Products.

With a policy of continuous product development Ancon Building Products reserves the right to modify product design and specification without due notice.



ISO 9001: 2008
FM 12226



ISO 14001: 2004
EMS 505377



OHSAS 18001: 2007
OHS 548992

